

TECHNICAL CATALOGUE



AUGUSTA EVO

Code **TC.2.003200.EN**

Version **E**

Date **25.06.2021**

LANDING AND CAR DOOR

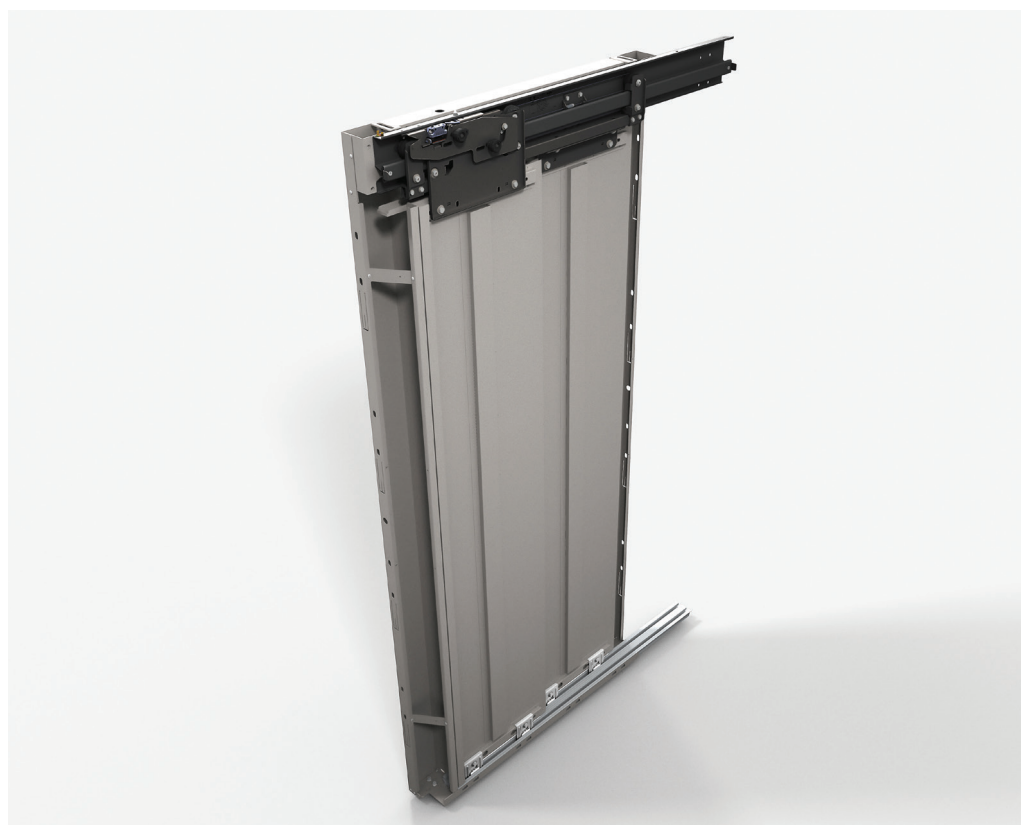

No part of this publication may be reproduced or translated, even in part, without prior written permission from WITTUR.

Subject to change without notice!

info@wittur.com
www.wittur.com

© Copyright WITTUR 2021

safety in motion™



GENERAL INDEX

TECNICAL DATA	
1.1	Application range Production range Fire certificates
1.2	Technical features
1.3	Technical data
1.4	Landing and car door arrangement
1.5	Operator fixing to car front wall
1.6	Operator fixing to car front wall (standard fixing)
1.7	Operator fixing on car roof (optional)
1.8	Opening and closing times (ECO Belt Drive)
1.9	Car door infill plate schedule Bottom fixing for car sill Slot position for car sill with holes (optional)
1.10	Position of the coupler between the landing lock rollers
1.11	Car door and landing door arrangement with coupler with car door lock
1.11.1	Car doors without car door lock (Optional)
1.12	Emergency opening device for coupler with car door lock
1.13	Maximum sizes push button box
1.13.1	Maximum sizes push button box detail for SB/SF>=145
1.14.1	Minimum standard distance between sill and lower mechanism
1.14.2	Minimum distance between sill and lower mechanism
1.15	Extra large floor thickness
Ty.11/12 - SIDE OPENING TWO PANELS LANDING DOOR	
2.1	Car door, Ty.12 CO=700÷1100
2.2	Fire-resistant door, Ty.11/R-L
2.3	Fire-resistant door with lateral big frames
2.4	Shaft wall for "niche installation"
2.5	Shaft wall for "wall installation"
2.6	Arrangement for fire-resistant door
Ty.01/02 - CENTER OPENING TWO PANELS LANDING DOOR	
3.1	Car door, Ty.02 CO=700÷1100
3.2	Fire-resistant door, Ty.01/R-L
3.3	Fire-resistant door with lateral big frames
3.4	Shaft wall for "niche installation"
3.5	Shaft wall for "wall installation"
3.6	Arrangement for fire-resistant door



GENERAL INDEX

FLOOR LINE FRAME

- 4.7 Floor line frame, Ty.01/C (optional)
Floor line frame, Ty.11/R-L (optional)

EQUIPMENTS

- 10.1.1 Brackets for TSW=20÷55 (niche installation), Ty.11/R-L
- 10.1.2 Brackets for TSW=56÷99 (niche installation), Ty.11/R-L
Brackets for TSW=100÷140 (wall installation), Ty.11/R-L
- 10.1.3 Brackets for TSW=80÷99 (niche installation) SP=100, Ty.11/R-L
- 10.1.4 Brackets for TSW=100÷140 (wall installation) SP=100, Ty.11/R-L
- 10.2.1 Brackets for TSW=20÷55 (niche installation), Ty.01/C
- 10.2.2 Brackets for TSW=56÷65 (niche installation), Ty.01/C
Brackets for TSW=66÷100 (wall installation), Ty.01/C
- 10.2.3 Brackets For TSW=85÷100 (wall installation) SP=100, Ty.01/C
- 10.3 Cover sill assembly between frames (optional)
- 10.4 Sill protection (optional)
- 10.5 Pit egress (optional)
- 10.6 Security switch for low pit access short pit and/or head (optional)
- 10.7 Lateral adjustment (optional)
- 10.8.1 WSE light curtain fixing for central opening car doors, Ty 02/C (optional)
- 10.8.2 WSE light curtain fixing for central opening car doors, Ty 12/R-L (optional)



APPLICATION RANGE

Drive	Usage Area
AUGUSTA EVO	Residential Buildings, Small Offices

PRODUCTION RANGE

CAR DOORS WITH BELT TRANSMISSION

AUGUSTA EVO LANDING DOORS		AUGUSTA EVO CAR DOORS		CO mm		CH mm	
TYPE	ILLUSTRATION	TYPE	ILLUSTRATION	Min.	Max.	Min.	Max.
TY 01/C		TY 02/C		700	1100	2000	2200
TY 11/R		TY 12/R					
TY 11/L		TY 12/L					

FIRE CERTIFICATES

EN81-58	BS 476-22	RUSSIA (**)	UKRAINE (**)	AUSTRALIA
E120 EI60 EI120 EW30 EW60 (*)	120'	E30 EI60	EI60	120'

(**) Available only for SB=SF=120 or 90.

(*) Cladded execution acc. to schedule below.

<p>SB=SF=90,100,120</p> <p>Ty.01: Cladded panels mandatory if CO > 900 or CH > 2100 Ty.11: Cladded panels mandatory if CO > 800 or CH > 2000</p>
<p>SB=SF=145</p> <p>Ty.01: Cladded panels and frame mandatory if CO > 800 or CH > 2100 Ty.11: Cladded panels and frame mandatory if CO > 750 or CH > 2000</p>
<p>BIG FRAME</p> <p>Ty.01: Cladded panels and frame always mandatory Ty.11: Cladded panels and frame always mandatory</p>



TECHNICAL FEATURES

Features:

- Narrow total package:
- **Car door + sill gap + landing door = 110mm (Ty.01-02/C)**
- **Car door + sill gap + landing door = 190mm (Ty.11-12/R-L)**
- Complies to LD95/16, 2014/33/EU and EN81, EN81-70, EN81-80 (SNEL), EN81-58, BS 476-22, AS 1530.4, PREN 81-8, **EN81-20/50**, Custom Union

Execution:

- Panel finish:
 - stainless steel brushed
 - stainless steel with pattern (leather, linen, rhomb, ...)
 - powder coated in RAL
 - galvanised finish
- Linear belt brushless drive ECO+
- Aluminium sill. [Valid for passengers application with GQ<=1350 Kg. Test load 40% GQ](#)
- Coversill
- Sill protection
- Floor line frame
- Lateral adjustment

Equipment (optional):

- WSE light curtain including fixing kit
- Emergency opening contact



TECHNICAL DATA

	ECO+
Motor Characteristics	AC 3 Phase Motor
Drive	V3F Converter
Rated Power	60W
Max Momentary Power Consumption	100W
Stand-by Power	2.5W
Power Supply	Univ. (127V; 2A) \pm 20% (230V; 1A) \pm 20% 50/60Hz
Noise Level (Door Operator)	average 55 dB, max 60 dB
Protection Class	IP20
Regulations and Standards	EN81, EN81-58, EN81-70, EN81-80 (SNEL), EN81-20/50 Lift directive 95/16/EC
Electromagnetic Compatibility	Immunity and Emission Protection acc. EN12015/16
Maximum Movable Masses (Car and Landing Door Panels)	130kg
Passenger Protective Device	Wittur Light Curtain



TECHNICAL DATA

	ECO+
Shaft Room Temperature	-0...+50°C
Storage Temperature	-5...+70°C
Humidity Range	<97%...<25°C <93%...40°C
Vibration (Test Value)	EN60068-2-6
Bump (Test Value)	EN60068-2-29
Self Learning	•
Supervision Function	•
Data Stored Permanently	•
Nudging (NUD)	•
Opening Push Button in the Car (Optional)	•
Protective Device - Power Supply	24V DC + 10% 150 mA
Emergency Battery Drive	18 - 26 VDC max 5A

- AVAILABLE

LANDING AND CAR DOOR ARRANGEMENT

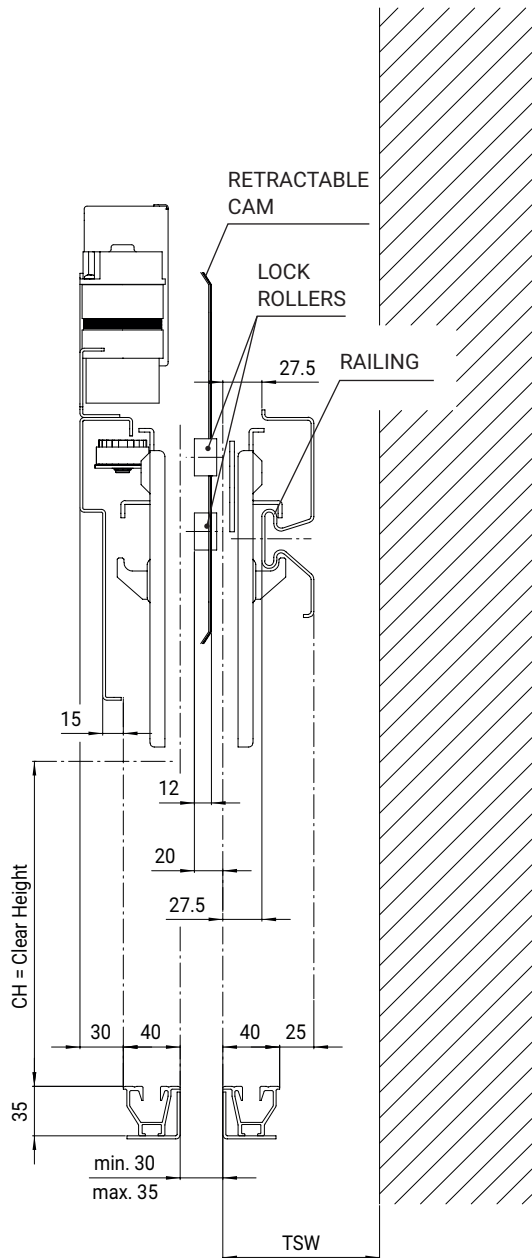

Ty 01/C Ty 02/C

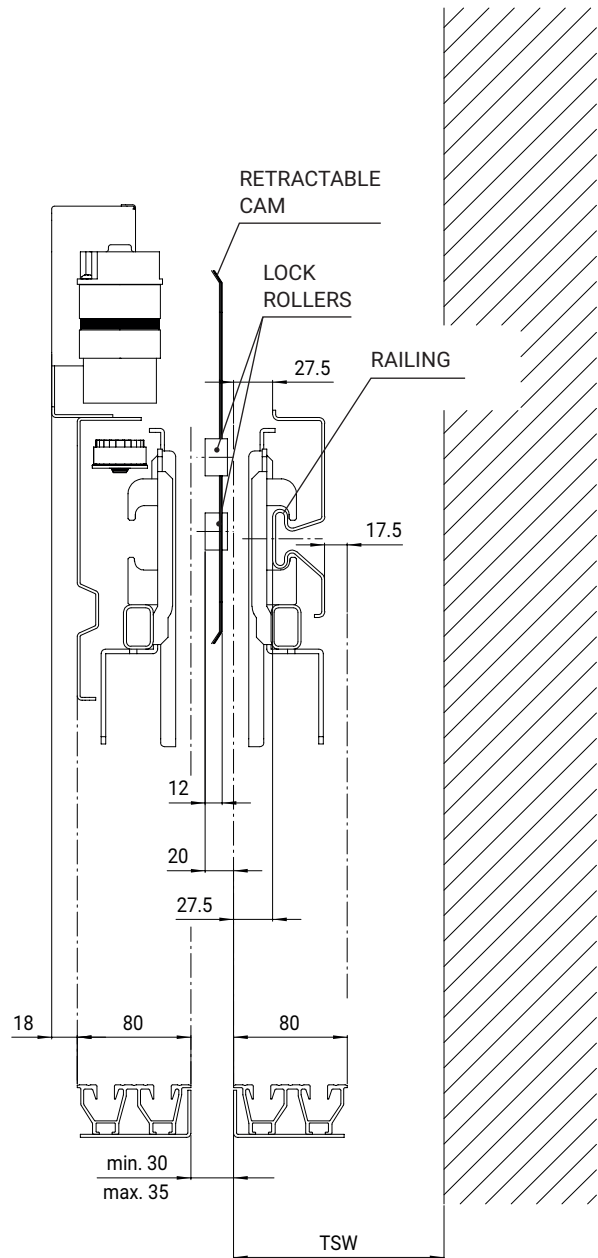

Ty 11/R-L Ty 12/R-L

OPERATOR FIXING TO CAR FRONT WALL

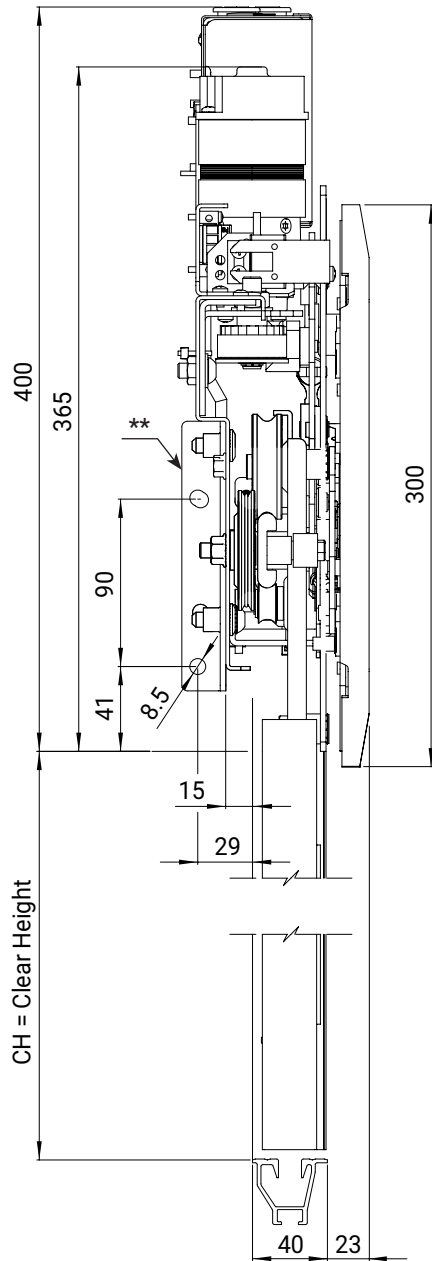

Ty 02/C

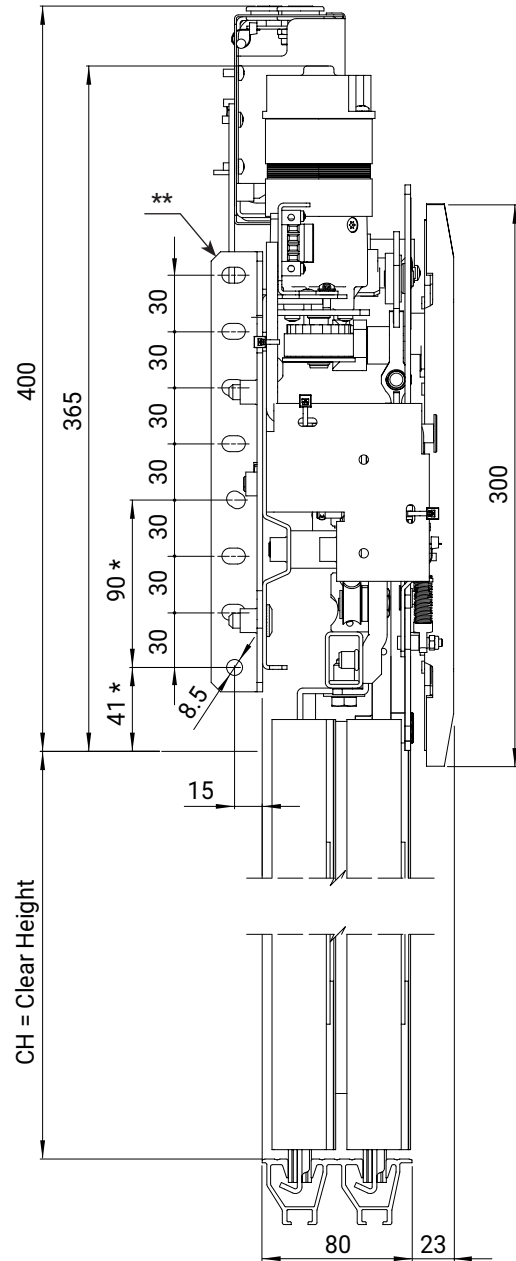

Ty 12/R-L

** Fixing point compatible with 3215-Augusta bracket.

* Standard fixing point.

** Fixing point compatible with 3215-Augusta bracket.

OPERATOR FIXING TO CAR FRONT WALL (OPTIONAL)

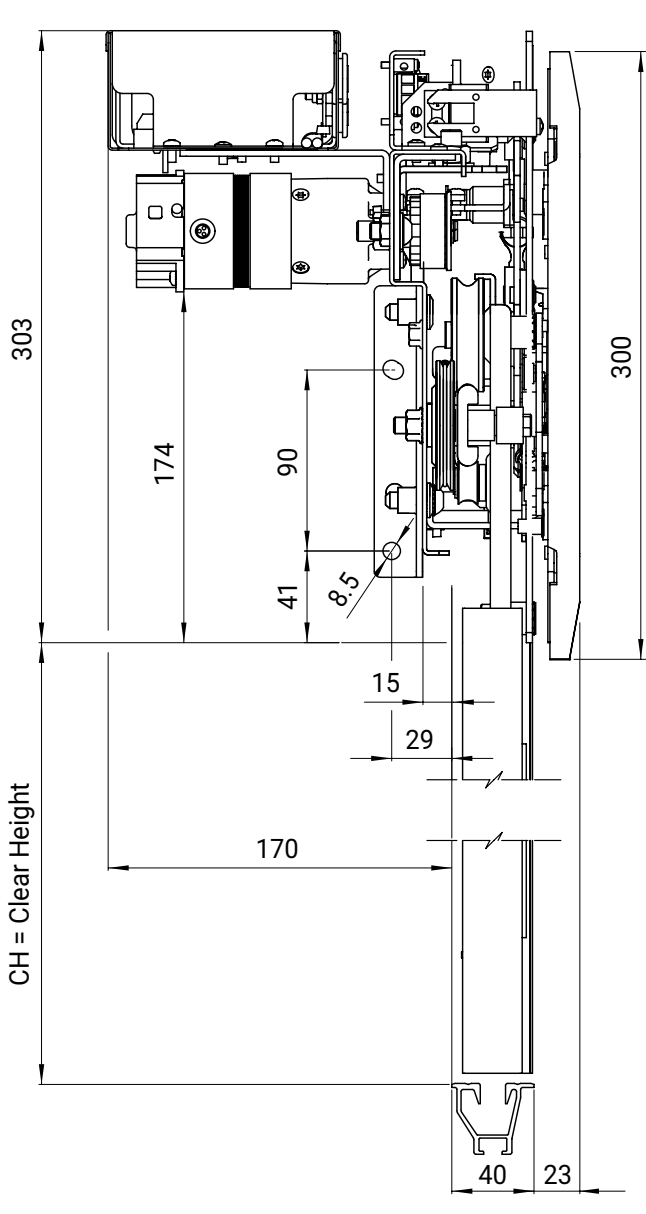

Ty 02/C

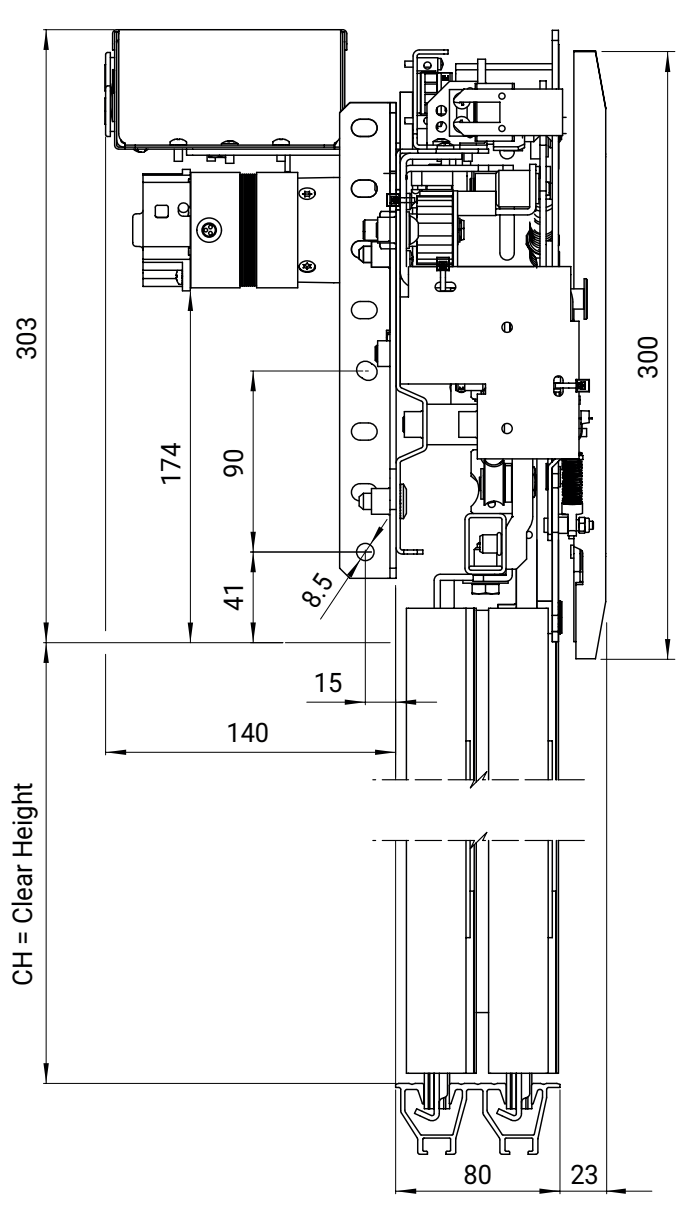



Ty 12/R-L

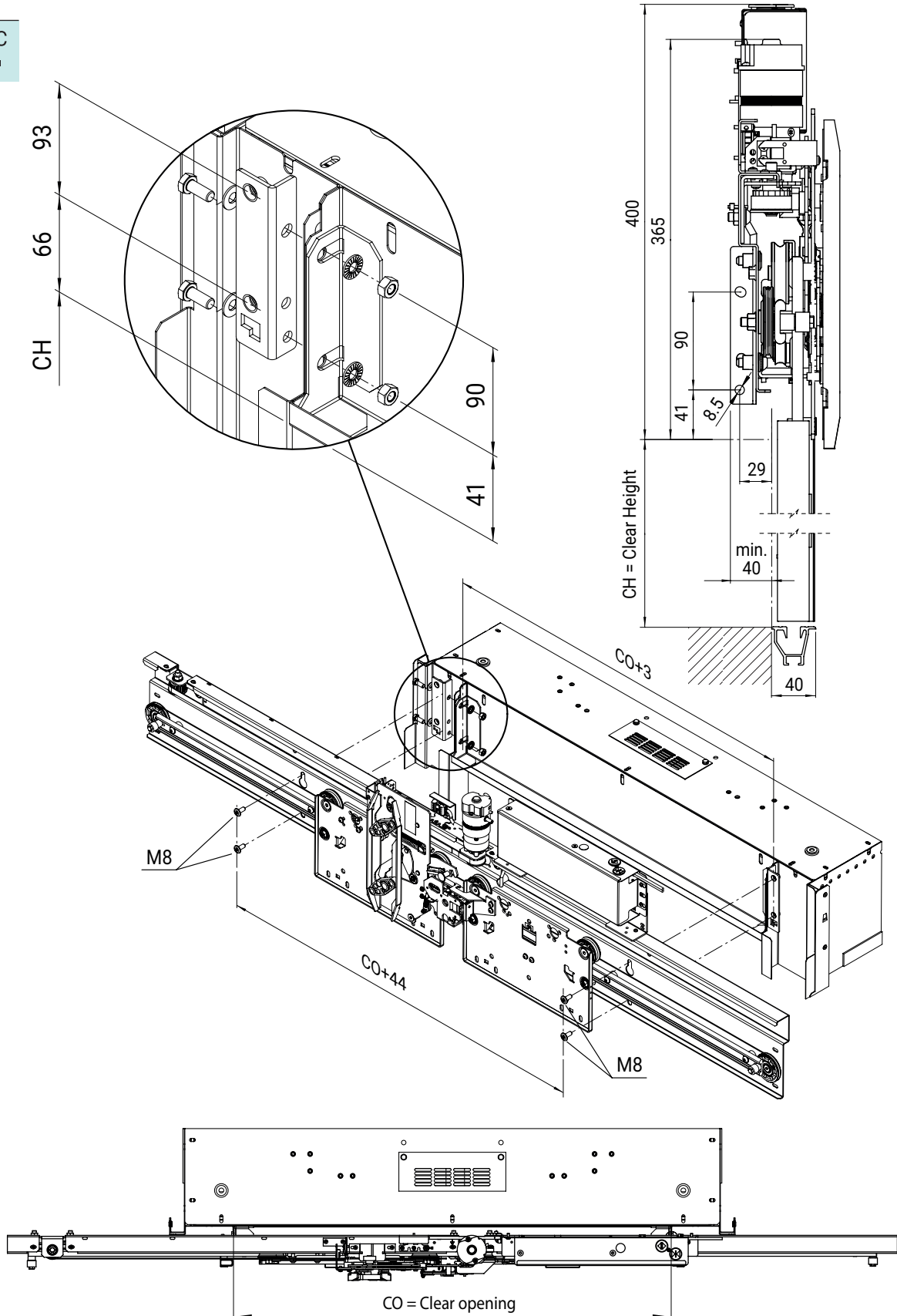

OPERATOR FIXING TO CAR FRONT WALL (STANDARD FIXING)

Ty 02/C



OPERATOR FIXING TO CAR FRONT WALL (STANDARD FIXING)

Ty 12/R-L

LEFT HAND	AS DRAWN
RIGHT HAND	SYMMETRICALLY OPPOSITE

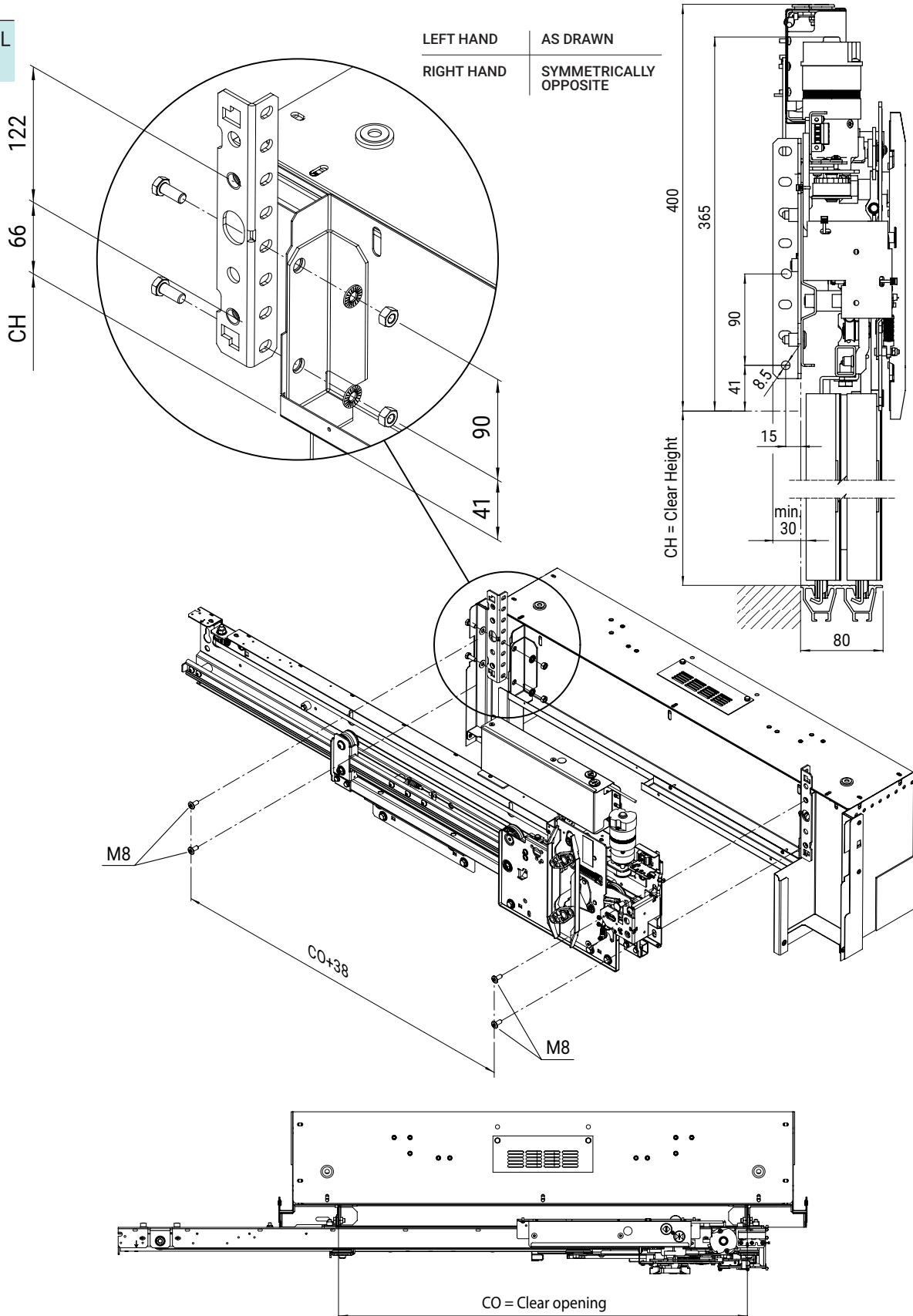

OPERATOR FIXING ON CAR ROOF (OPTIONAL)

VALID FOR $50 \leq HW \leq 200$
 (OPTION A)

VALID FOR $200 < HW \leq 283$
 (OPTION B)

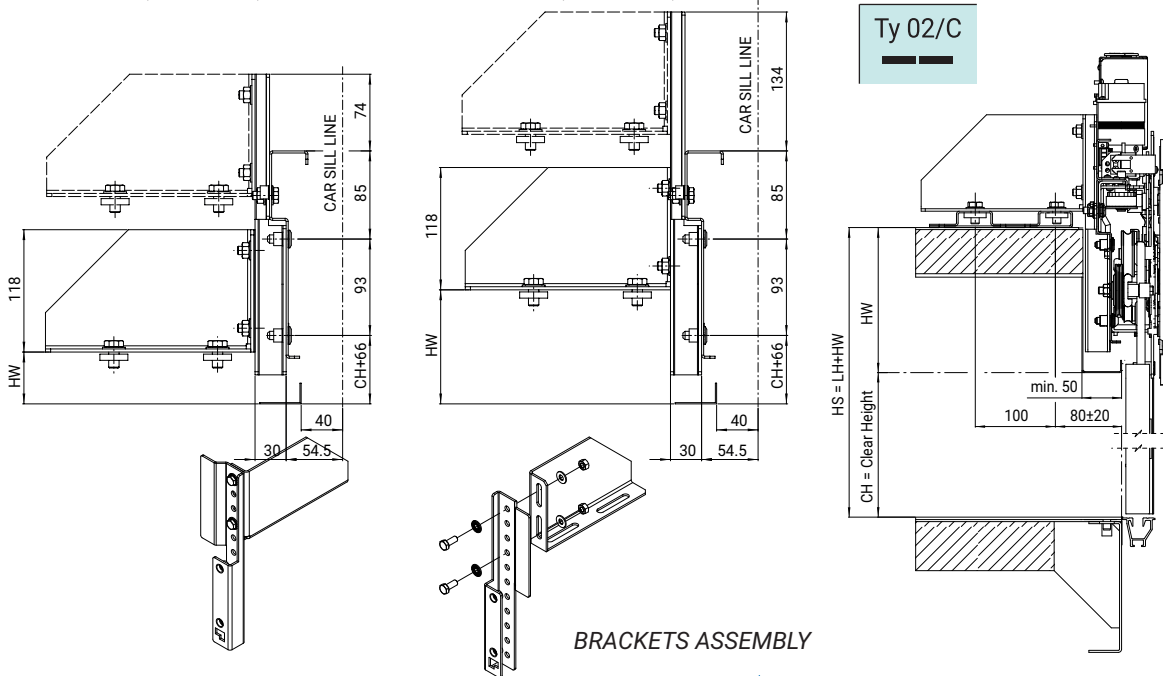

BRACKETS ASSEMBLY

FIXING ON CAR ROOF

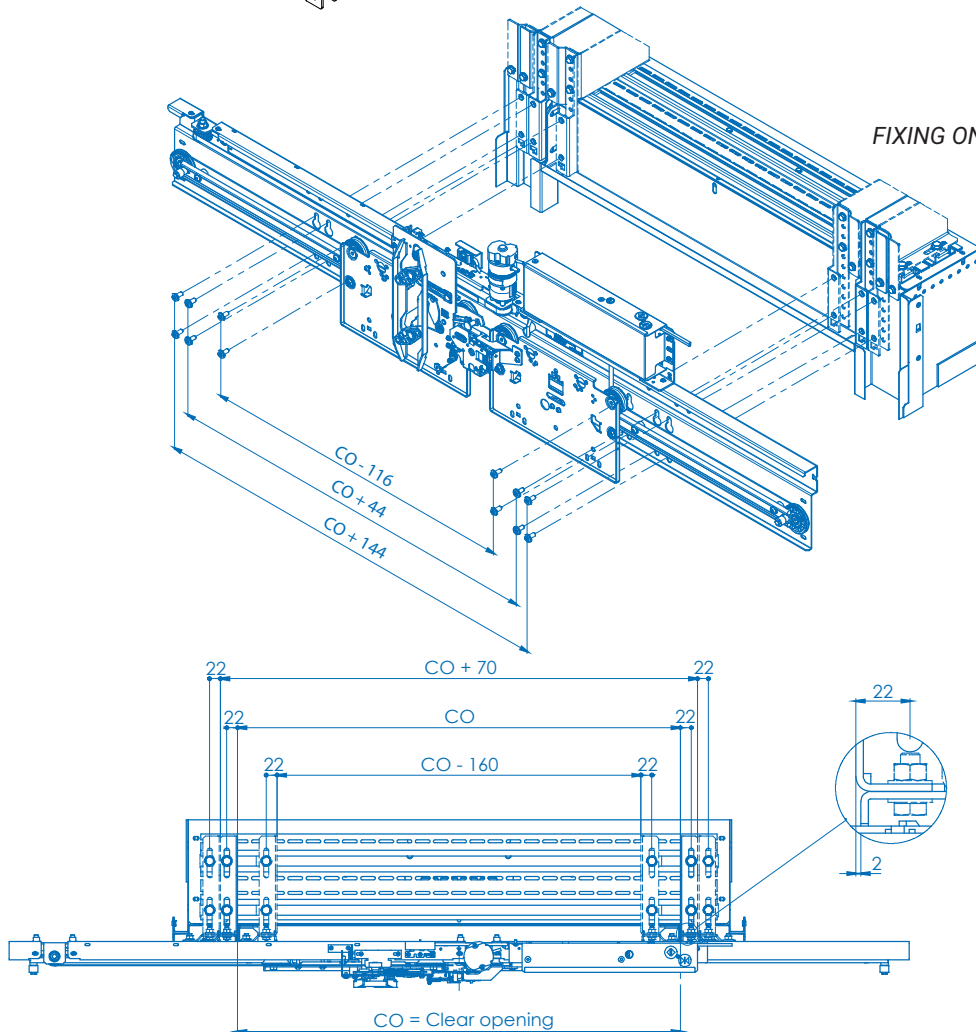

OPERATOR FIXING ON CAR ROOF (OPTIONAL)

VALID FOR $50 \leq HW \leq 200$
 (OPTION A)

VALID FOR $200 < HW \leq 283$
 (OPTION B)

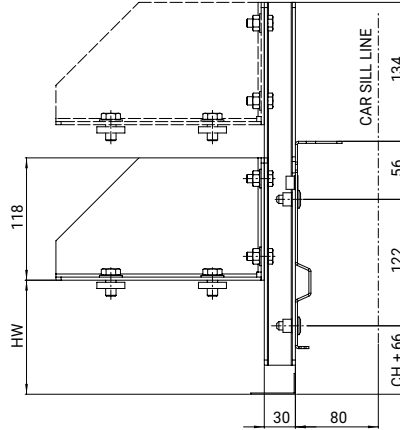
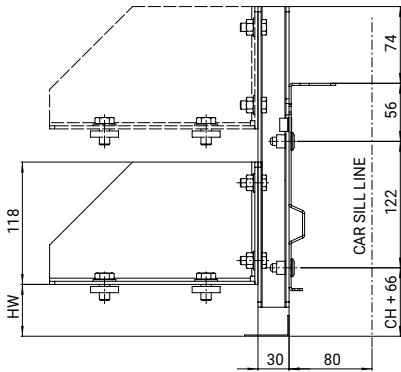

Ty 12/R-L

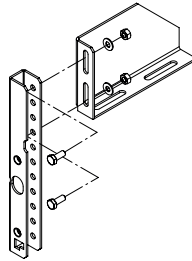
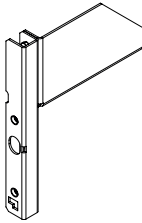
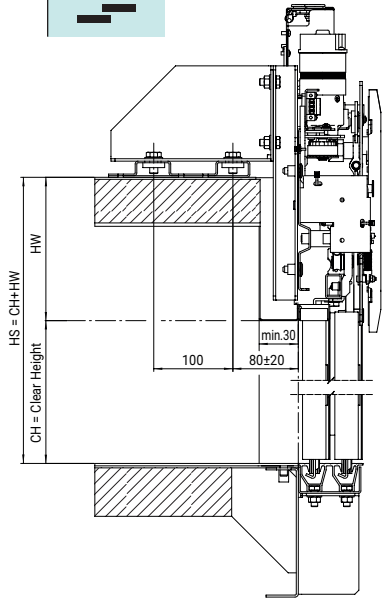

BRACKETS ASSEMBLY

FIXING ON CAR ROOF

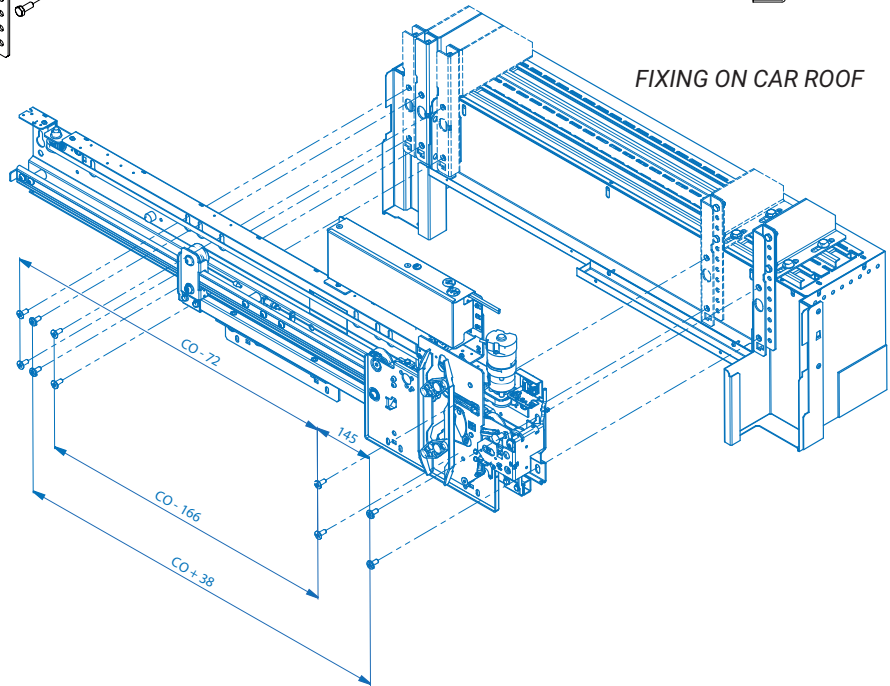

LEFT OPENING	AS DRAWN
RIGHT OPENING	SYMMETRICALLY OPPOSITE

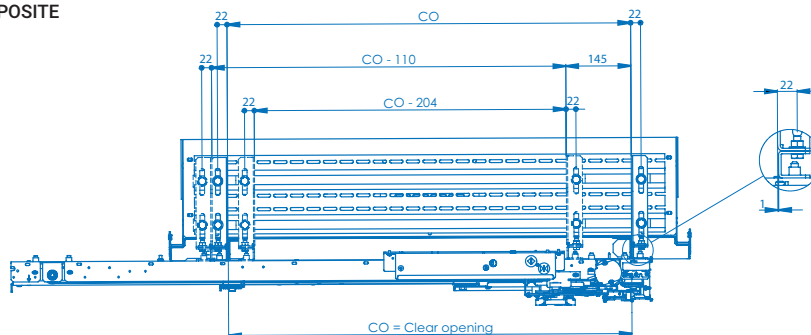

OPENING AND CLOSING TIMES (ECO Belt Drive)

TYPE C.O.	02/C			12/R-L		
	OPENING TIME	CLOSING TIME	CLOSING AVERAGE SPEED	OPENING TIME	CLOSING TIME	CLOSING AVERAGE SPEED
	s	s	m/s	s	s	m/s
700	2,1	3,0		2,8	4,1	
750	2,2	3,1		2,9	4,3	
800	2,2	3,1		3,0	4,4	
850	2,3	3,2		3,1	4,6	
900	2,4	3,3	0,30	3,2	4,8	0,30
950	2,5	3,4		3,3	5,0	
1000	2,5	3,5		3,4	5,1	
1050	2,6	3,6		3,6	5,3	
1100	2,6	3,6		3,8	5,4	

TYPE C.O.	02/C			12/R-L		
	OPENING TIME	CLOSING TIME	CLOSING AVERAGE SPEED	OPENING TIME	CLOSING TIME	CLOSING AVERAGE SPEED
	s	s	m/s	s	s	m/s
700	2,1			2,8	4,1	
750	2,2			2,9	4,3	
800	2,2			3,0	4,4	
850	2,3			3,1	4,6	
900	2,4	4,0	*	3,2	4,8	0,30
950	2,5			3,3	5,0	
1000	2,5			3,4	5,1	
1050	2,6			3,6	5,3	
1100	2,6			3,8	5,4	



* DEPENDENT ON CLOSING TIME

CAR DOOR INFILL PLATE SCHEDULE

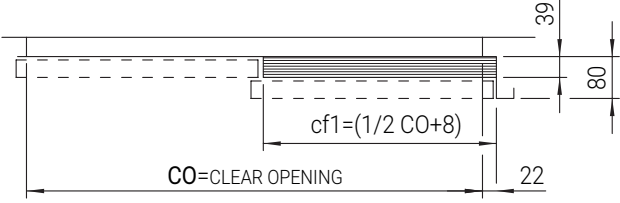

CO=clear opening
 $cf1 = (1/2 CO + 8)$

Ty 12/R-L

CO	cf1
700	358
750	383
800	408
850	433
900	458
950	483
1000	508
1050	533
1100	558

BOTTOM FIXING FOR CAR SILL

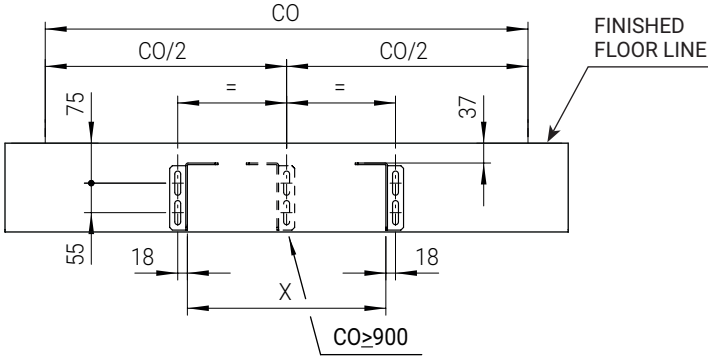

FINISHED FLOOR LINE

Ty 02/C

Ty 12/R-L

CO	X
700	360
750	460
800	560
850	660
900	760
950	
1000	
1050	
1100	

SLOT POSITION FOR CAR SILL WITH HOLES (OPTIONAL)

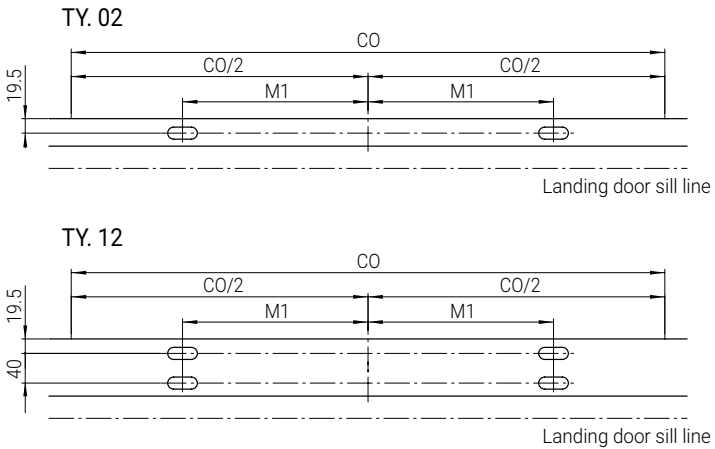

TY. 02

TY. 12

Landing door sill line

Ty 02/C

Ty 12/R-L

CO	M1
700	200
750	225
800	250
850	275
900	300
950	325
1000	350
1050	375
1100	400

POSITION OF THE COUPLER BETWEEN THE LANDING LOCK ROLLERS

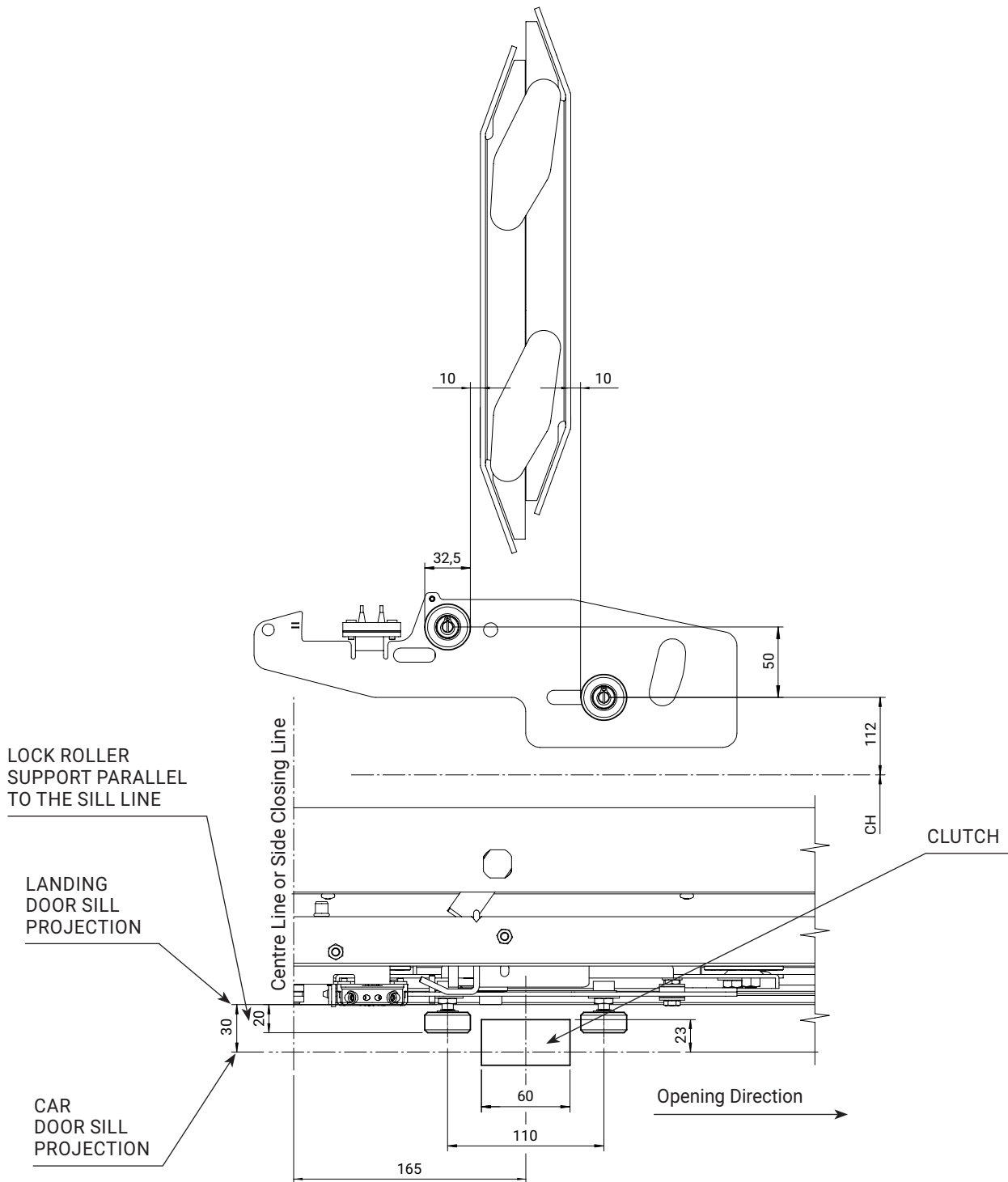

CAR DOOR AND LANDING DOOR ARRANGEMENT WITH COUPLER WITH CAR DOOR LOCK

Car stops in landing door zone:
 The rollers are detected. They operate the lock vane and the latch opens.

Car stops out of landing door zone:
 No rollers are detected. The lock vane is not touched and the latch keeps closed.

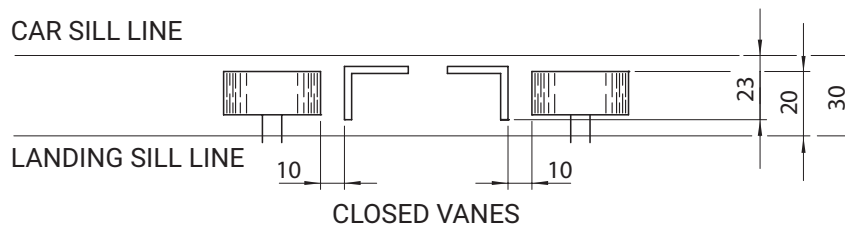
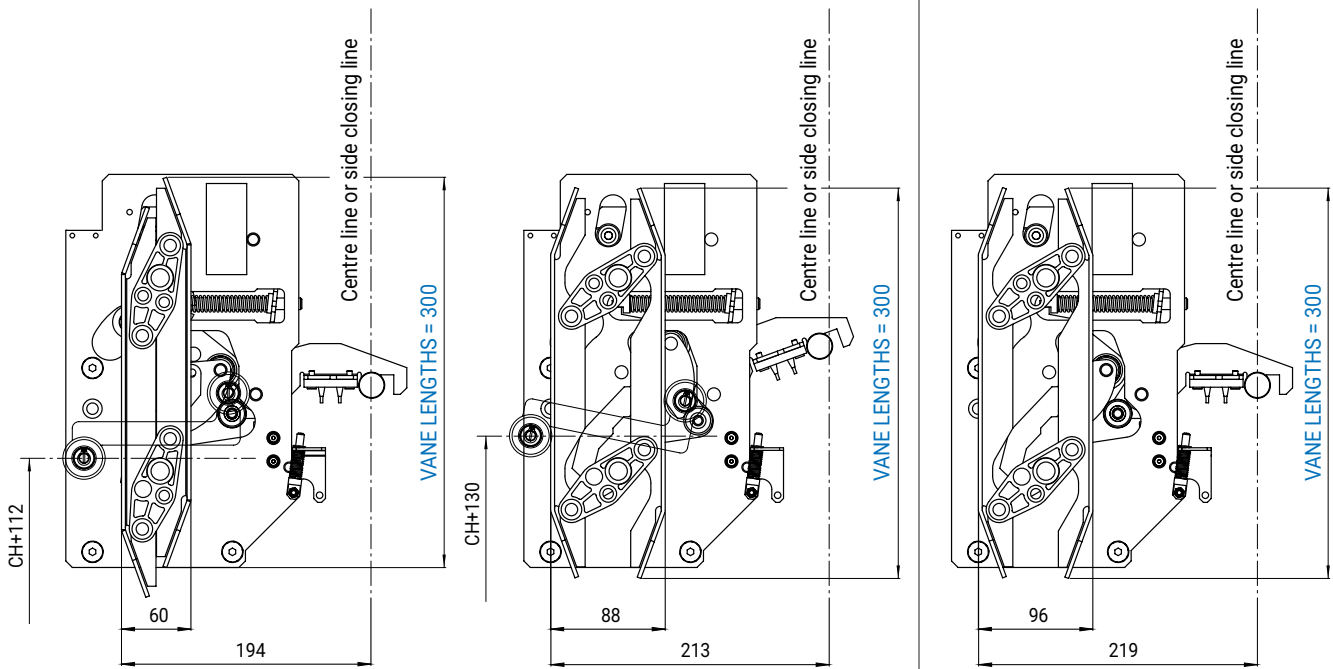

CAR DOORS WITHOUT CAR DOOR LOCK (OPTIONAL)

Not valid for EN81-20/50 applications
 300mm VANES

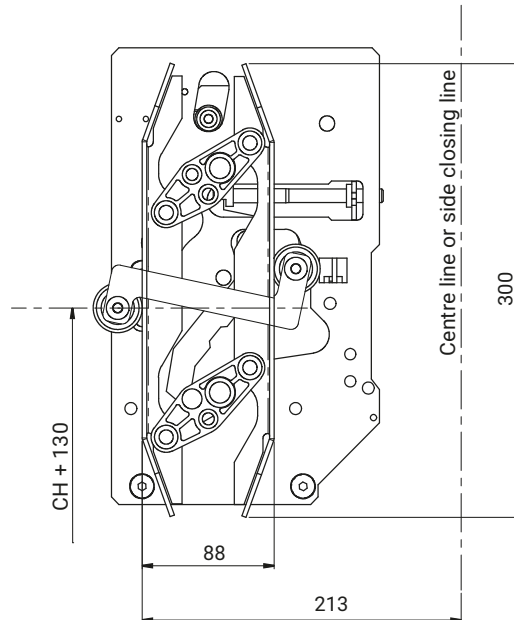
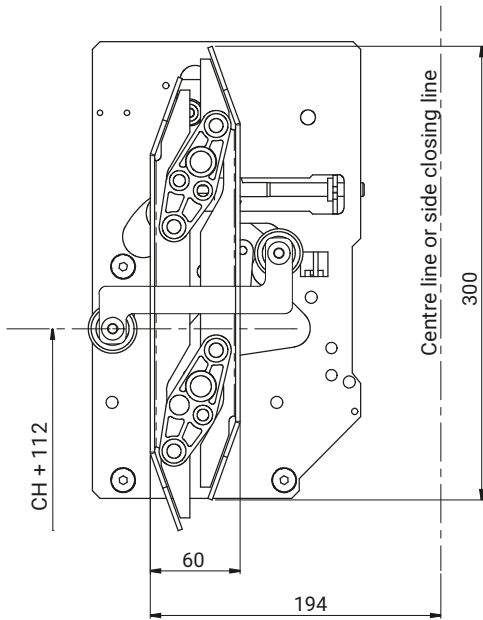

100mm VANES

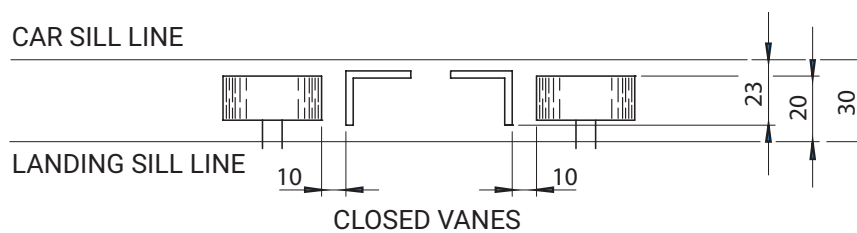
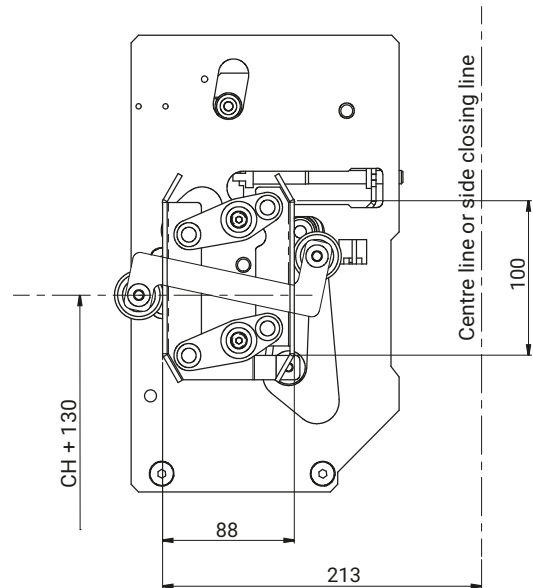
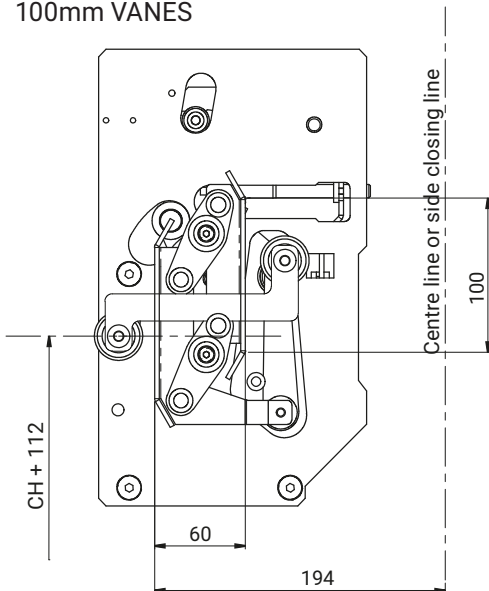

EMERGENCY OPENING DEVICE FOR COUPLER WITH CAR DOOR LOCK

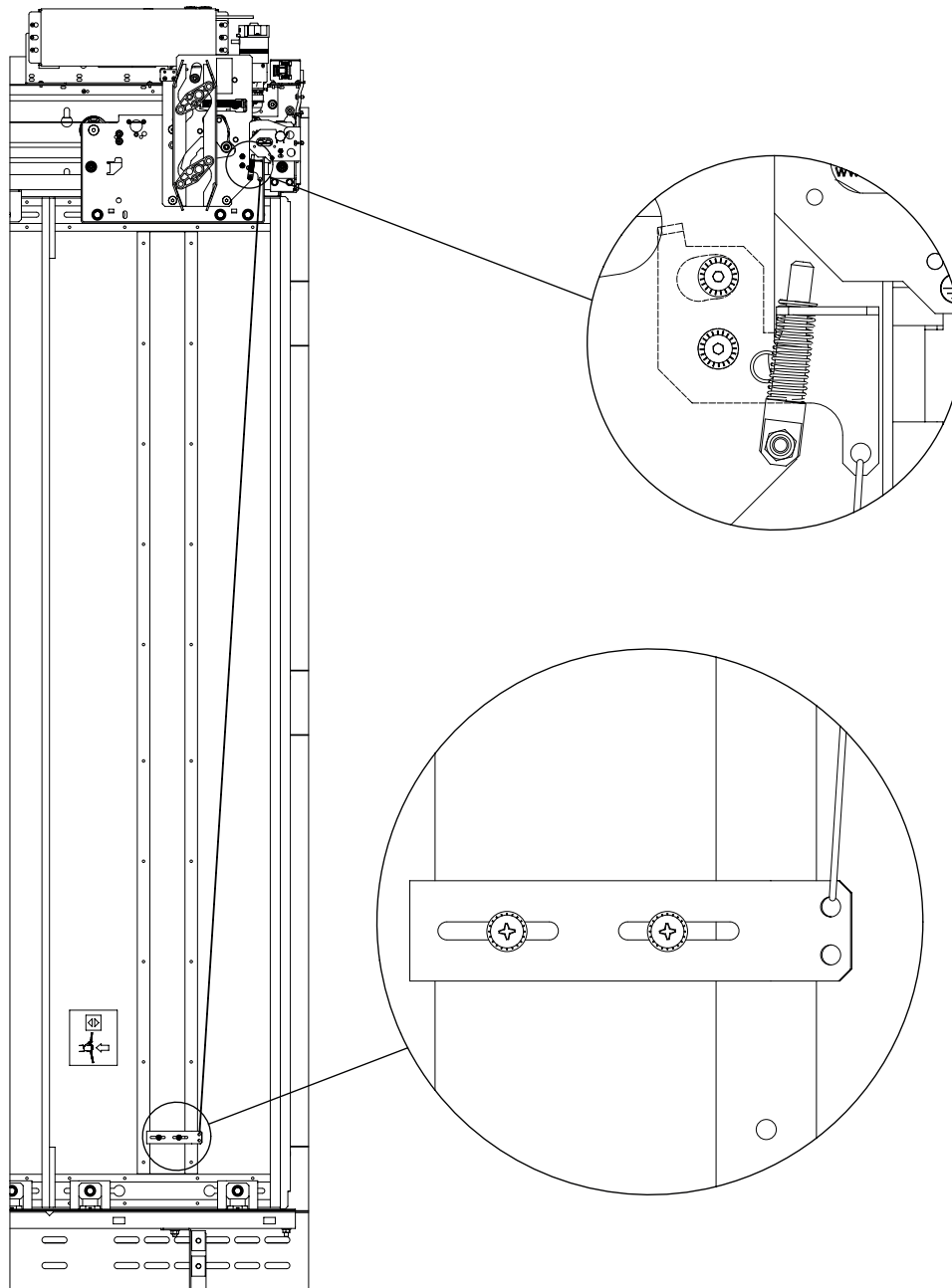

The rope of the car door emergency opening device is fixed to the bottom end of the door panel.
By pulling the rope, the car door lock is unlocked.

MAXIMUM SIZES PUSH BUTTON BOX

T 01

X-X Section

T 11

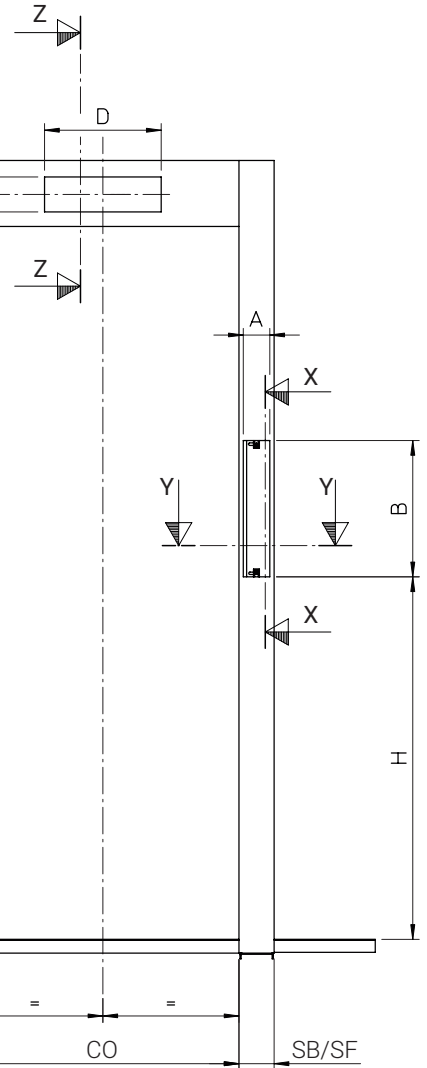
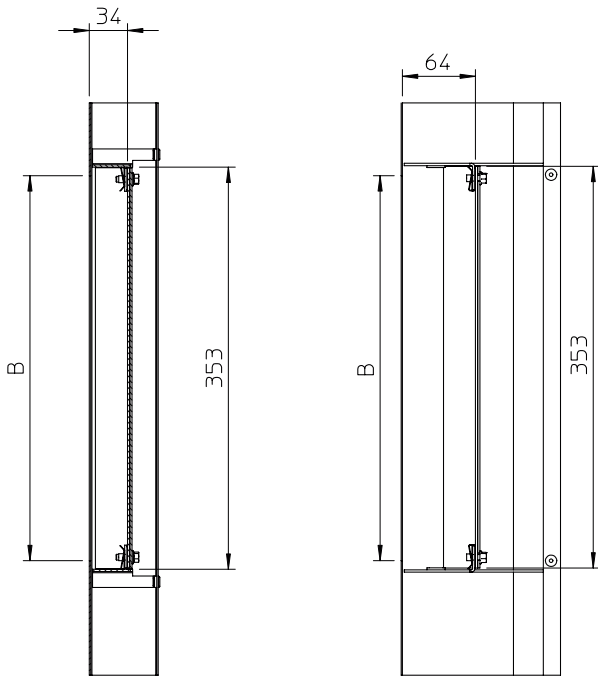

T 01

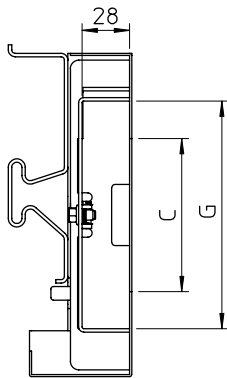

T 01

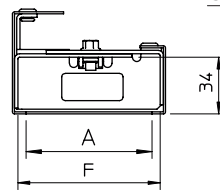

T 11

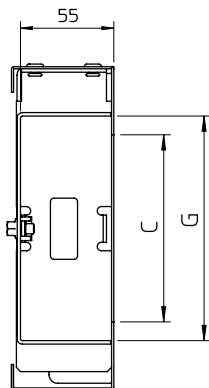

T 11

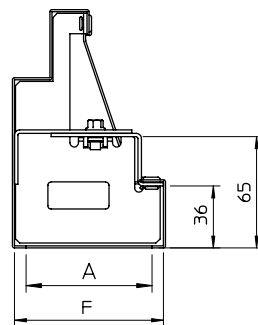

A	max. 74 for SB/SF=90 or SB/SF >=145 max. 78 for SB/SF=100 max. 98 for SB/SF=120
B	max. 350
C	max. 140 for SP=190 max. 50 for SP=100
D	max. 300
F	max. 83 for SB/SF=90 or SB/SF >=145 max. 93 for SB/SF=100 max. 113 for SB/SF=120
G	max. 150 for SP=190 max. 60 for SP=100

Z-Z Section

Y-Y Section

MAXIMUM SIZES PUSH BUTTON BOX. DETAIL FOR SB/SF>=145

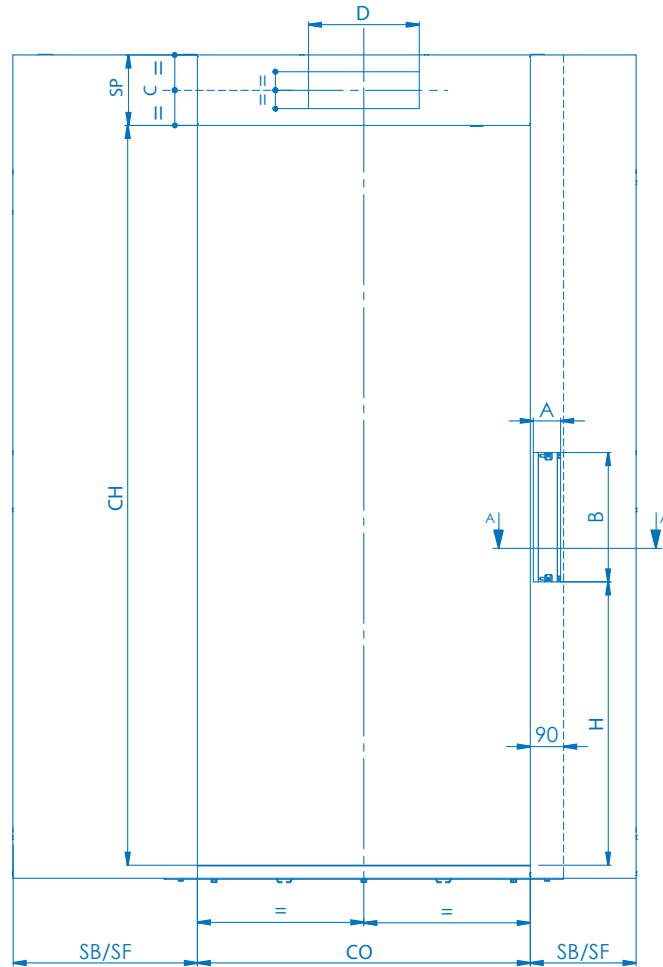

T 01

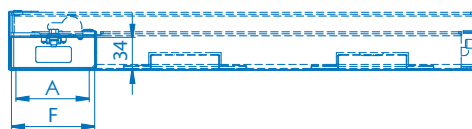

T 11

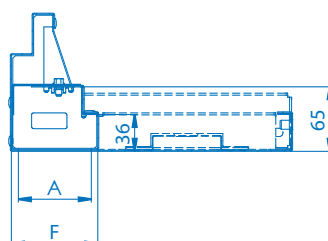

MINIMUM STANDARD DISTANCE BETWEEN SILL AND LOWER MECHANISM

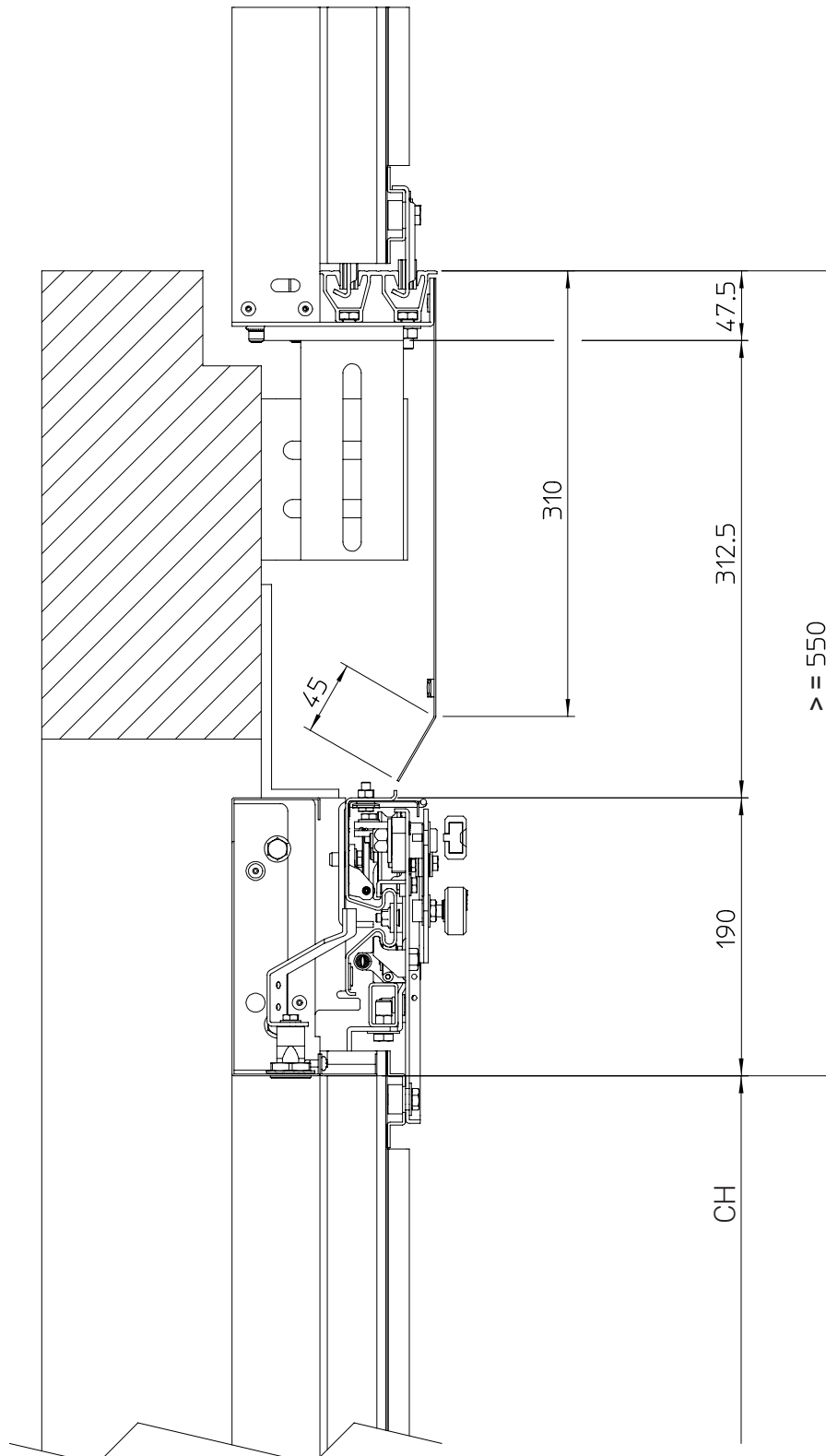

MINIMUM DISTANCE BETWEEN SILL AND LOWER MECHANISM

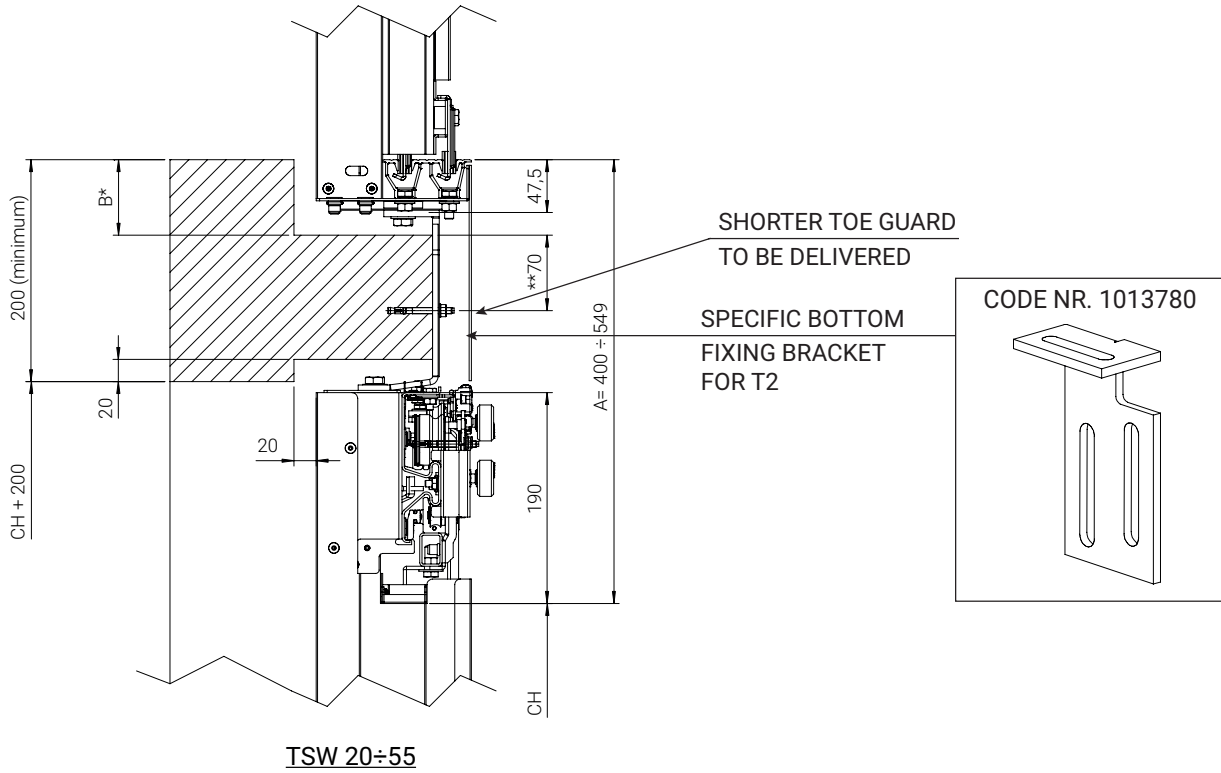

* B min 70 mm
 B max see table below

A	Max. finish floor B
400 ÷ 439	= A - 330
440 ÷ 549	110

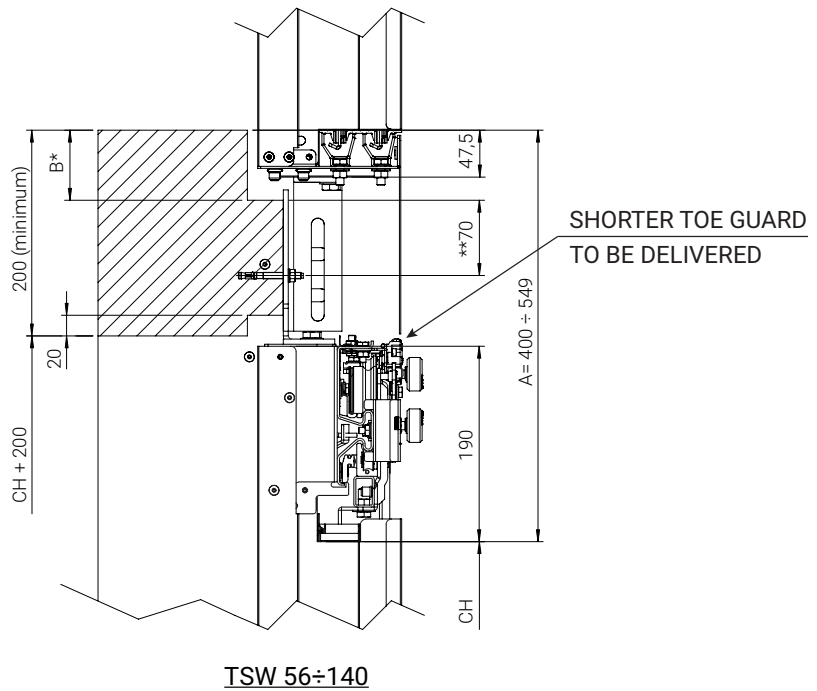

** For sill fixing brackets fixed with hilti bolts

EXTRA LARGE FLOOR THICKNESS

STANDARD FIXING BRACKETS

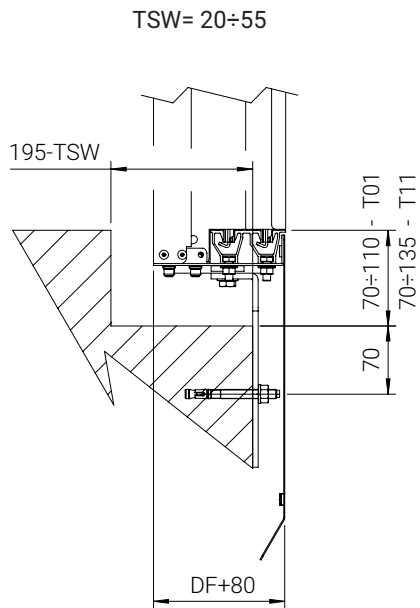

SPECIFIC FIXING BRACKETS

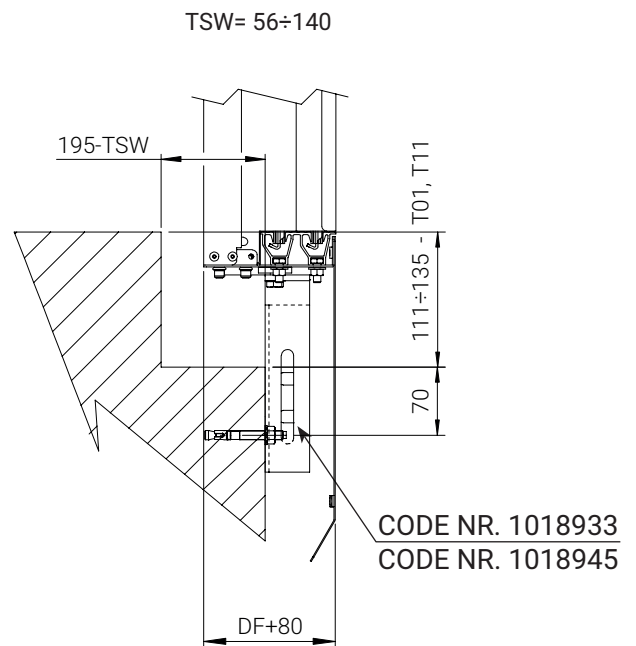
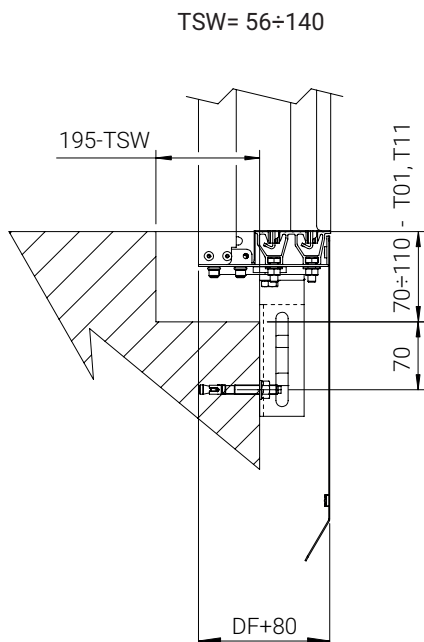
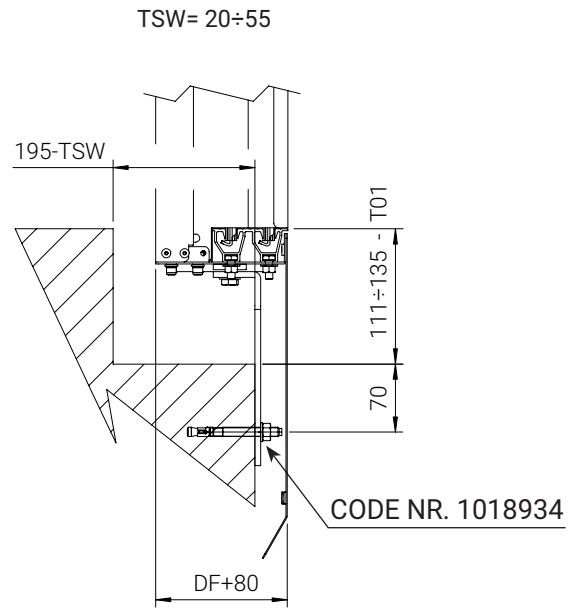

CAR DOOR, CO=700÷1100

Ty 12/R-L

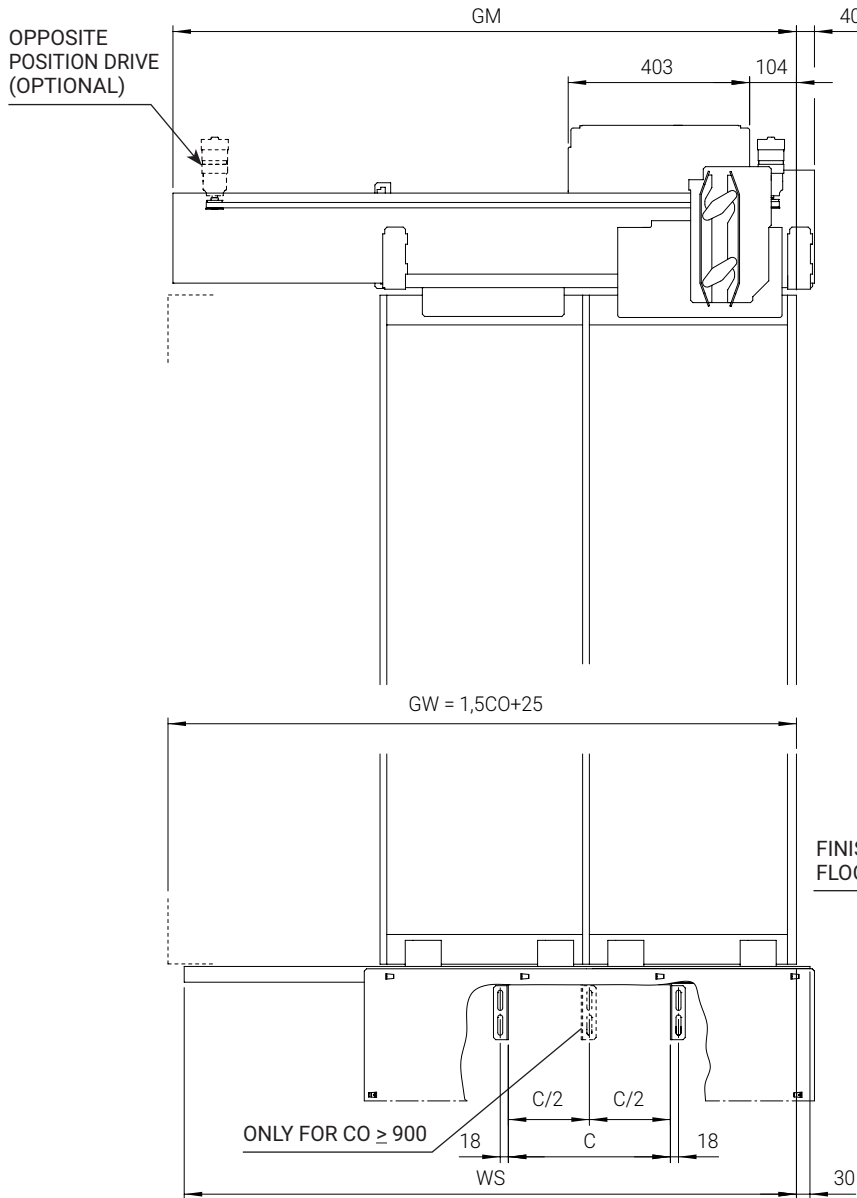

OPERATOR FIXING TO THE CAR FRONT WALL
 DETAIL PAGE 1.6.1

OPERATOR WITH HORIZONTAL POSITION
 SEE PAGE 1.5.2 (OPTIONAL)

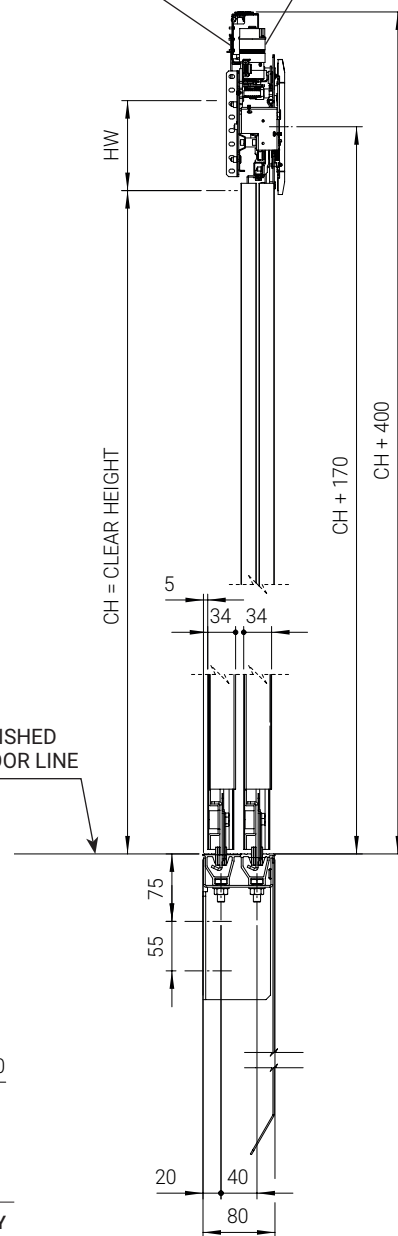

LEFT HAND | AS DRAWN
 RIGHT HAND | SYMMETRICALLY OPPOSITE

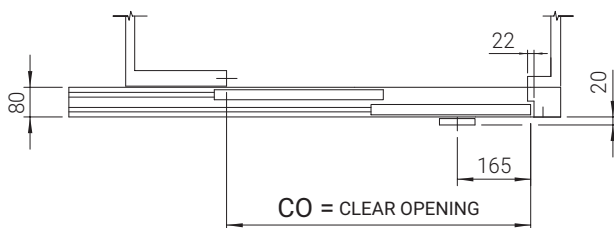

CO	NO COMPLETE DOOR WEIGHT Kg LH=2000	GM	GW	WS	C
* 700	61	1110	1075	1060	360
* 750	63	1185	1150	1135	460
800	66	1235	1225	1210	
850	68	1285	1300	1285	560
* 900	72	1385	1375	1360	
950	74	1435	1450	1435	660
* 1000	78	1535	1525	1510	
1050	80	1585	1600	1585	760
1100	83	1635	1675	1660	

(*) Caution: GM dimension larger than GW dimension

Note: Weights referring to not clad doors

FIRE-RESISTANT DOOR

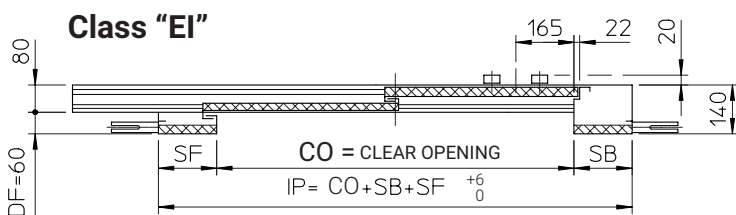
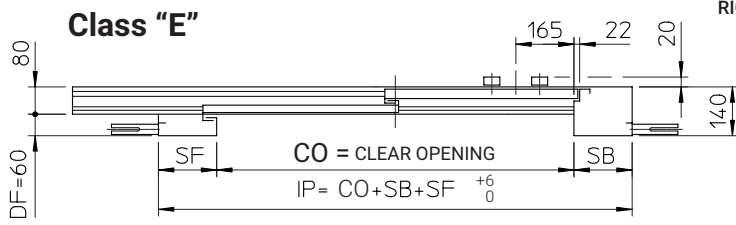
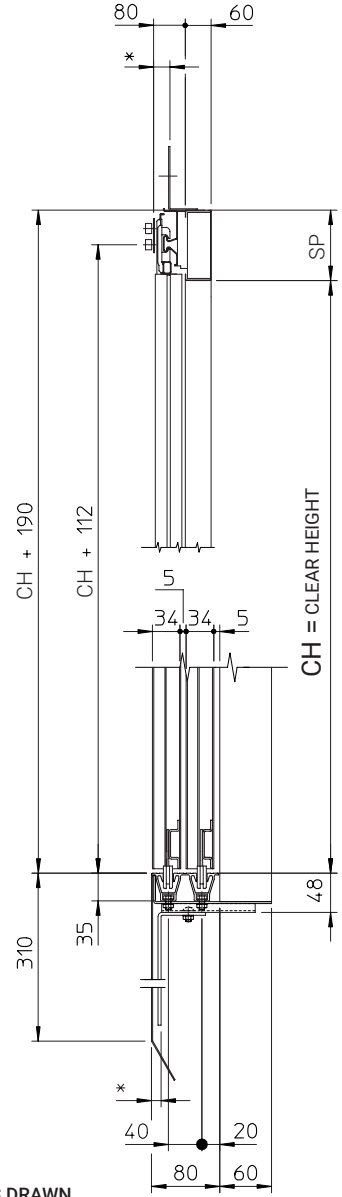
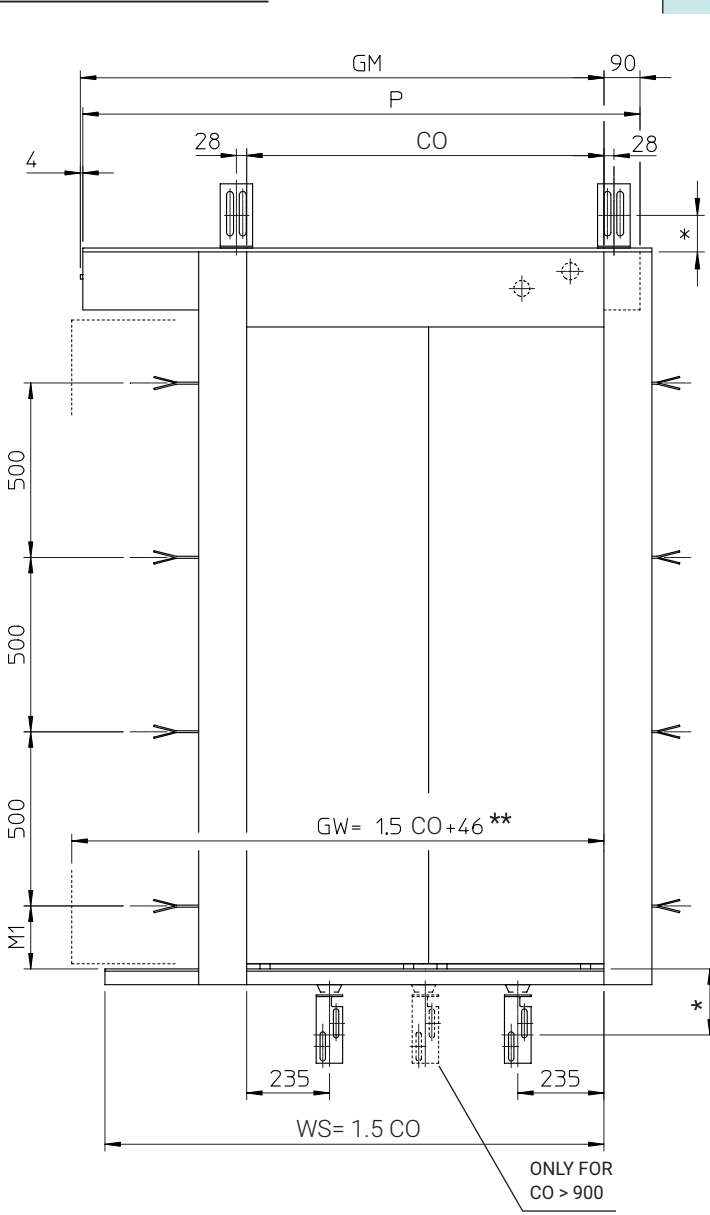
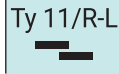

LEFT HAND AS DRAWN
RIGHT HAND SYMMETRICALLY OPPOSITE

CH	M1	FRAME	SB	SF	SP	DF
		2000	292	90x60	90	90
2100	342	100x60	100	100	100	60
2200	392	120x60	120	120	190	60

(*) See page 10.1.1, 10.1.2, 10.1.3 and 10.1.4
(**) Claded panel +1 / EI panel +4.

CO	GM	P	GW	WS
700	1109	1195	1096	1050
750	1184	1270	1171	1125
800	1234	1320	1246	1200
850	1284	1370	1321	1275
900	1384	1470	1396	1350
1000	1534	1620	1546	1500
1100	1634	1720	1696	1650

FIRE-RESISTANT DOOR WITH LATERAL BIG FRAMES

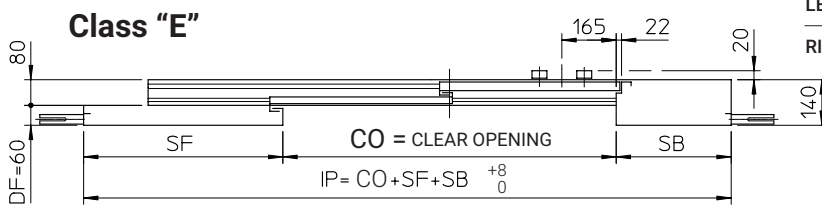
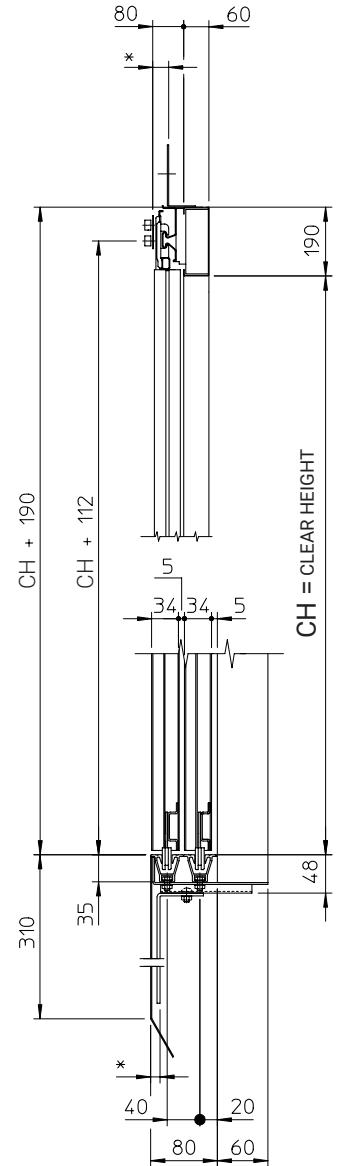
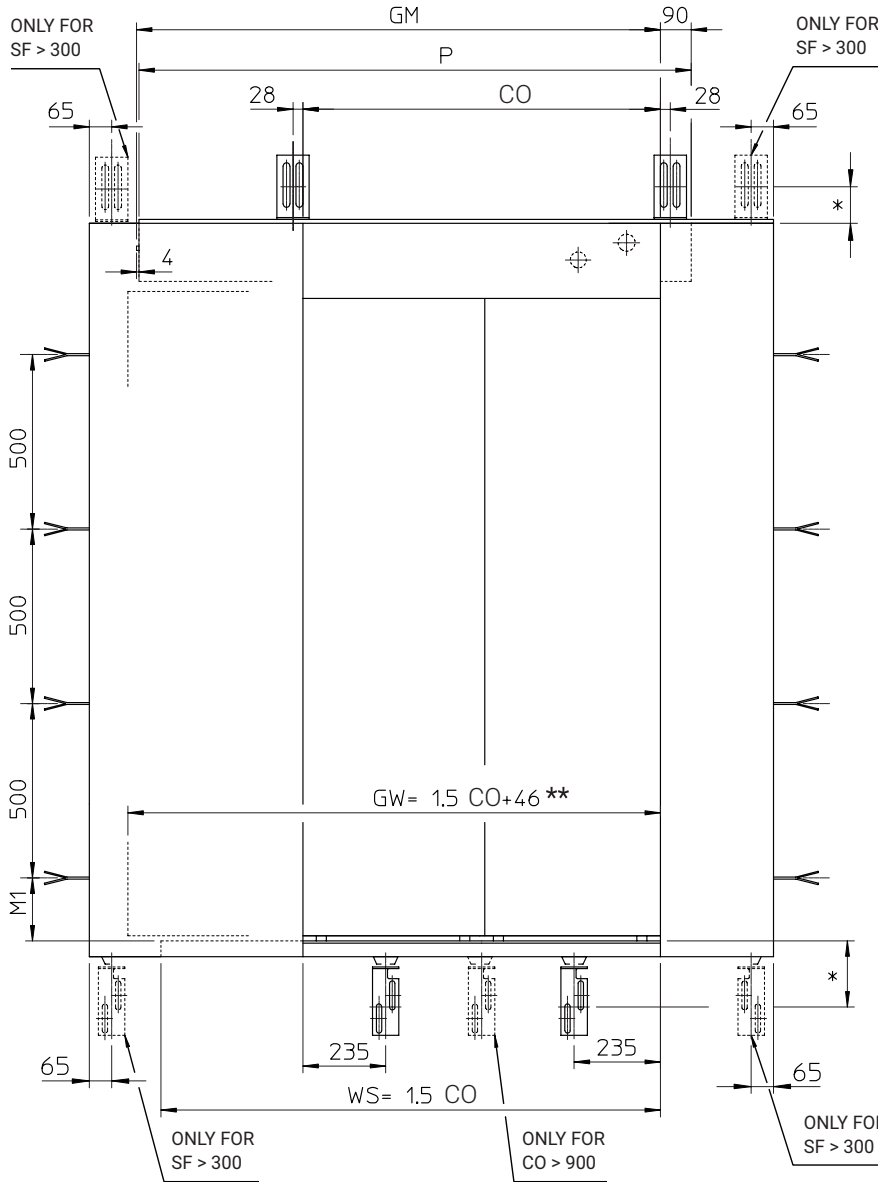

LEFT HAND AS DRAWN
RIGHT HAND SYMMETRICALLY OPPOSITE

CH	M1
2000	292
2100	342
2200	392

(*) See page 10.1.1 and 10.1.2
(**) Claded panel +1 / EI panel +4.

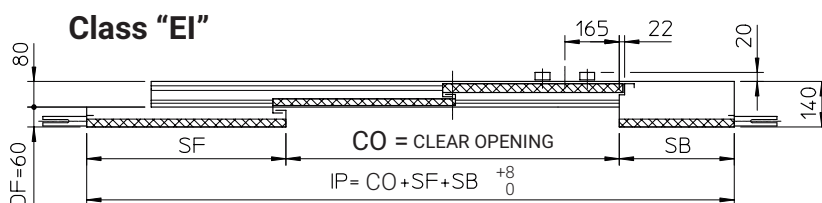

CO	GM	P	GW	WS
700	1109	1195	1096	1050
750	1184	1270	1171	1125
800	1234	1320	1246	1200
850	1284	1370	1321	1275
900	1384	1470	1396	1350
1000	1534	1620	1546	1500
1100	1634	1720	1696	1650

SF/SB min 145 max 650 (5 mm steps)

SHAFT WALL FOR "NICHE INSTALLATION"

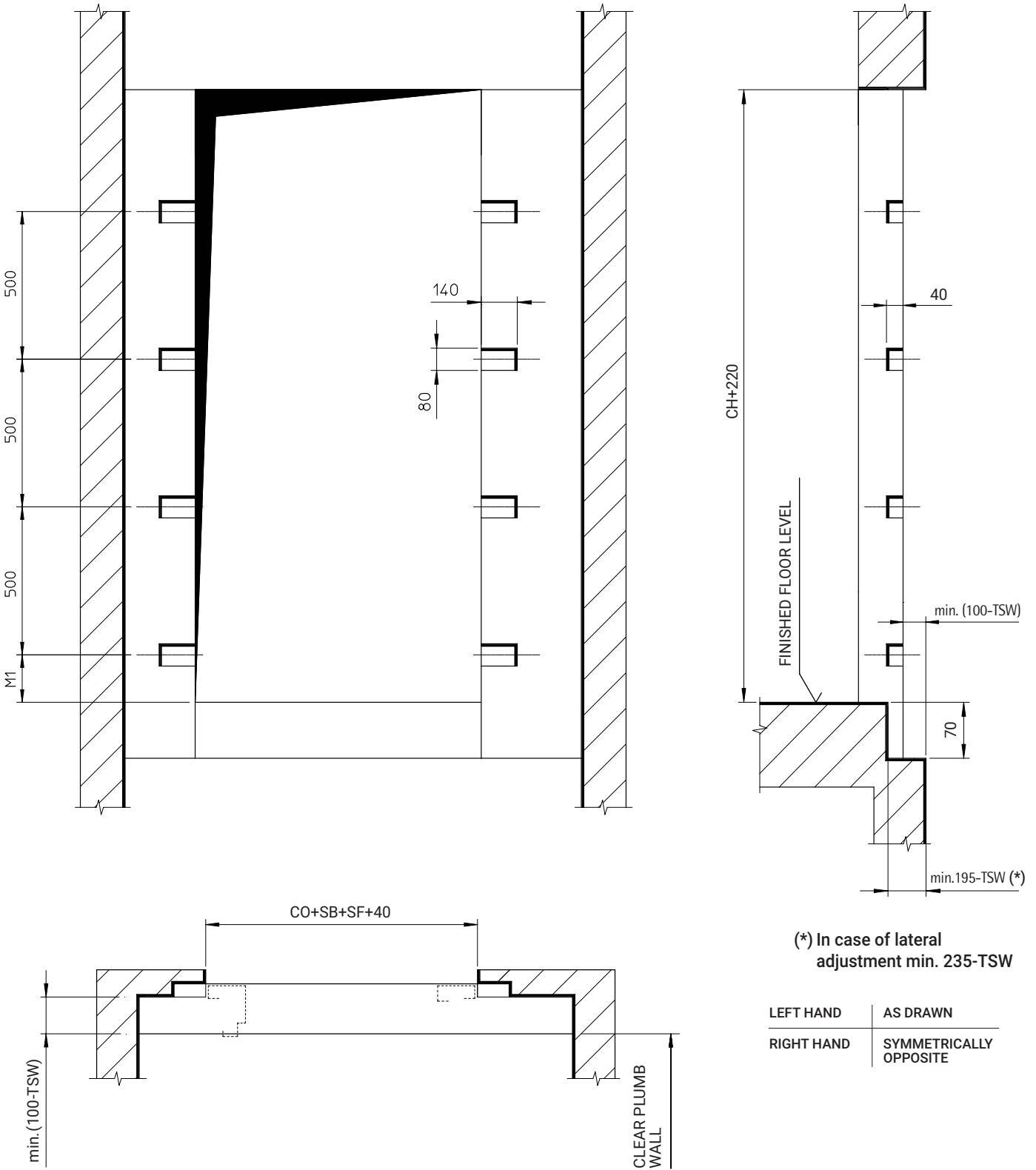

(* In case of lateral adjustment min. 235-TSW

LEFT HAND	AS DRAWN
RIGHT HAND	SYMMETRICALLY OPPOSITE

SHAFT WALL FOR "WALL INSTALLATION"

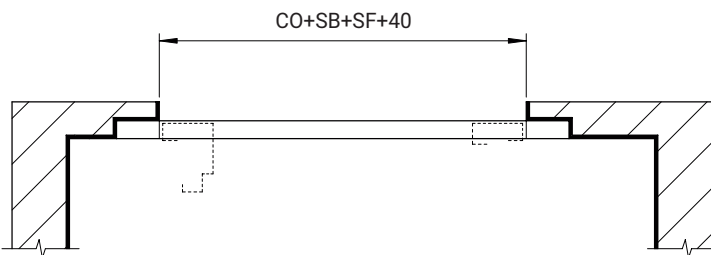
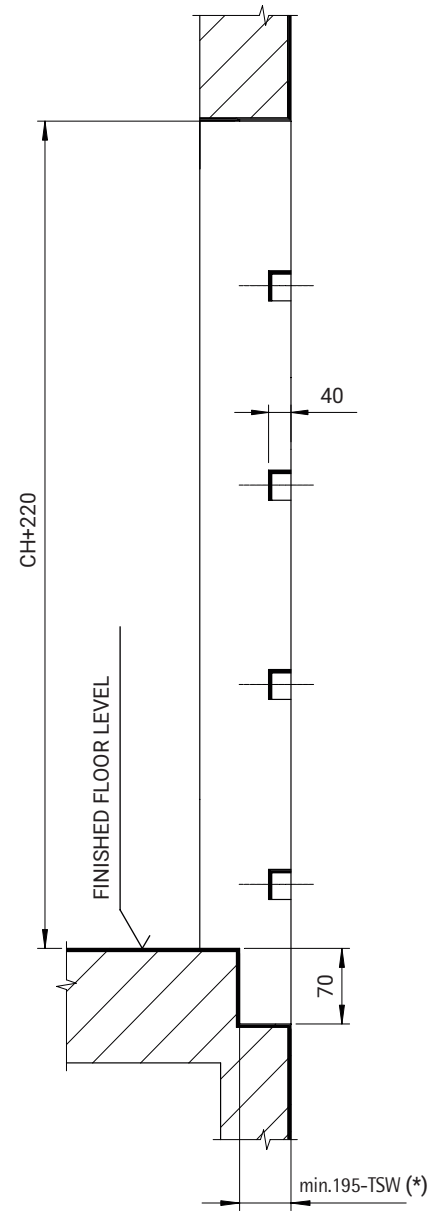
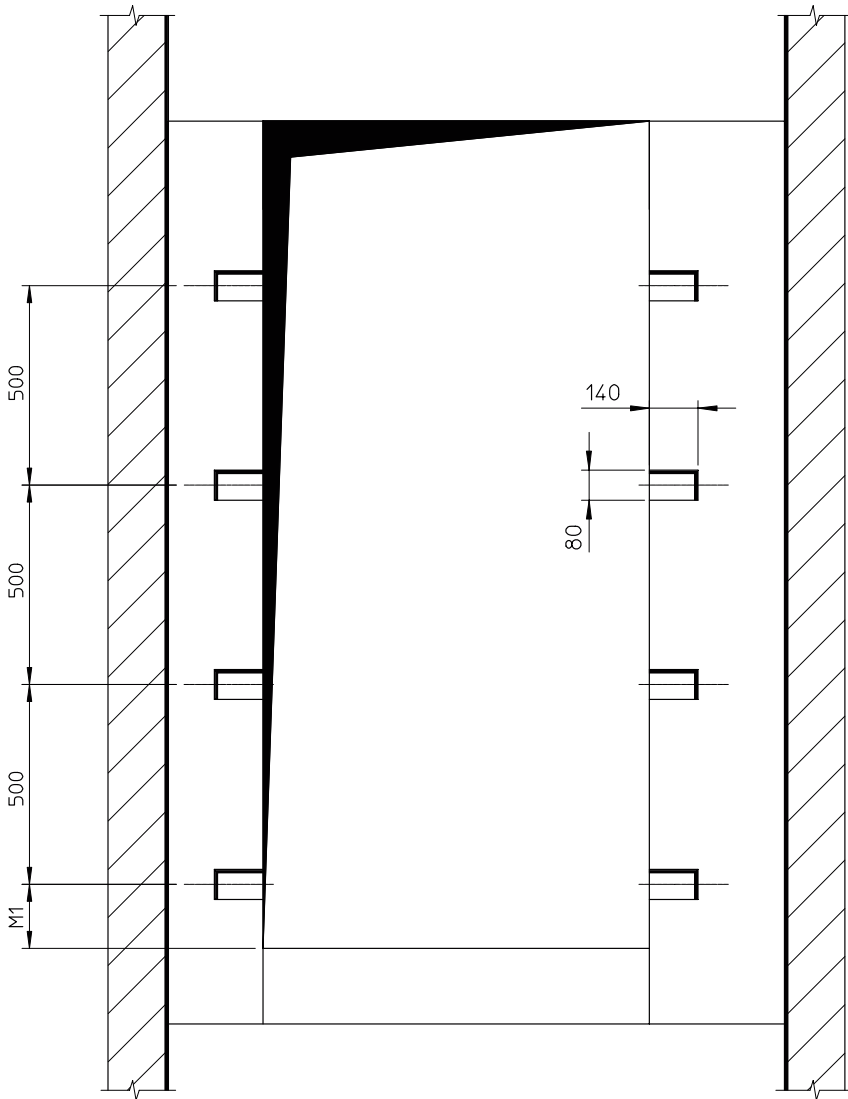
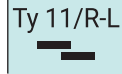

(*) In case of lateral adjustment min. 235-TSW

ARRANGEMENT FOR FIRE-RESISTANT DOOR

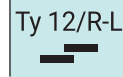

WALL INSTALLATION (TSW = 100÷140)

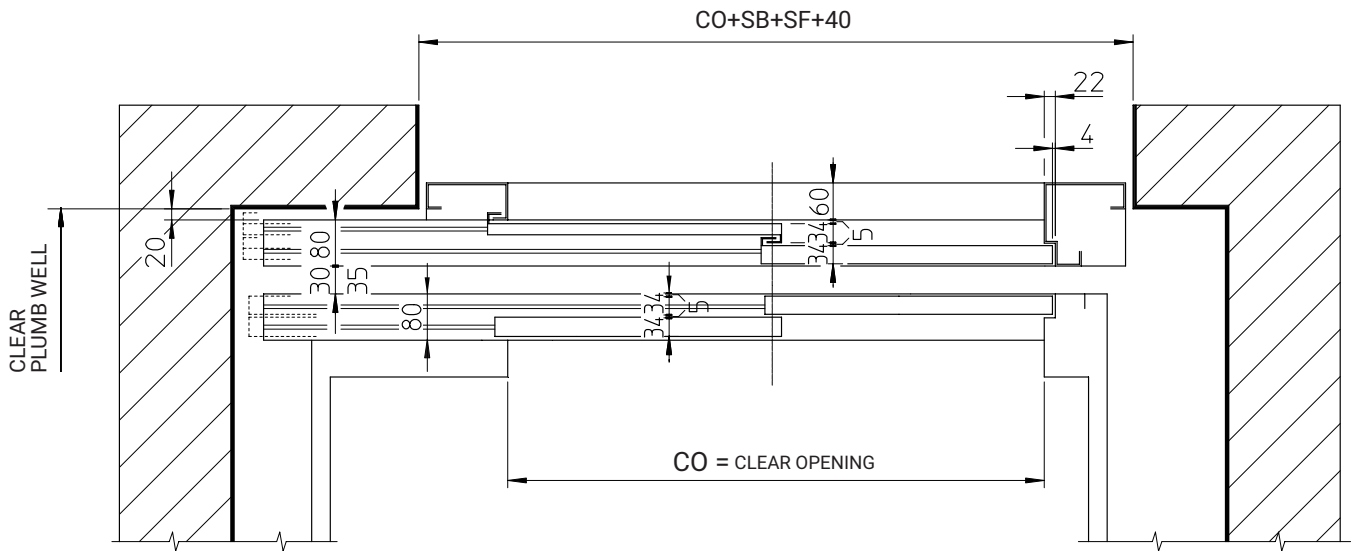

NICHE INSTALLATION (TSW = 20÷99)

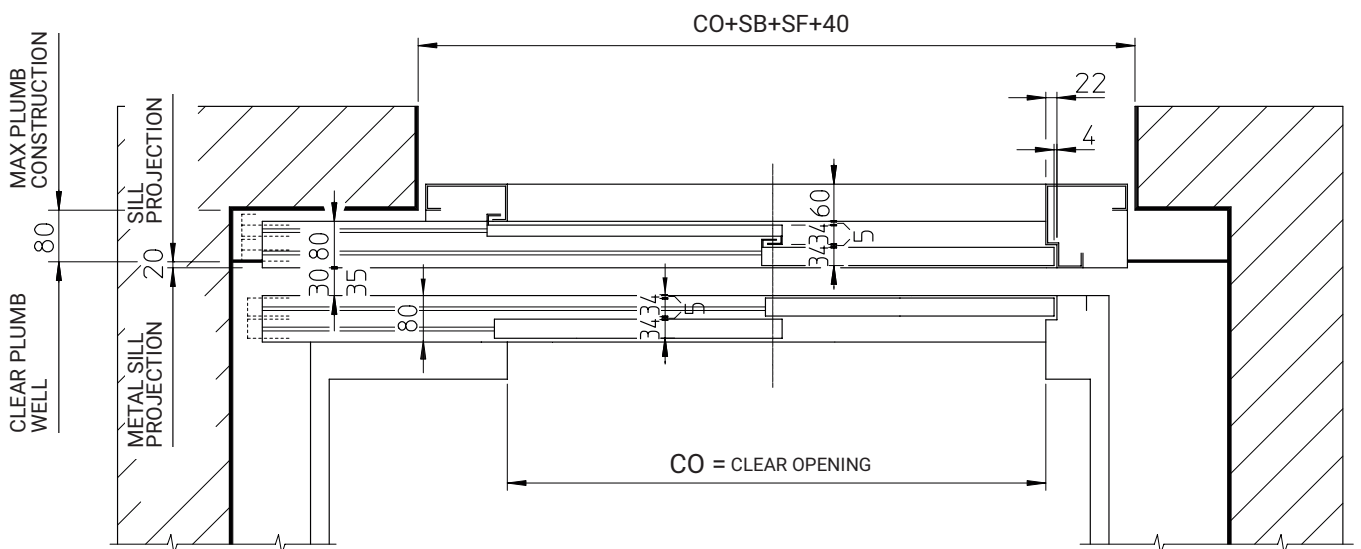

LEFT HAND	AS DRAWN
RIGHT HAND	SYMMETRICALLY OPPOSITE

CAR DOOR, CO=700÷1100

Ty 02/C

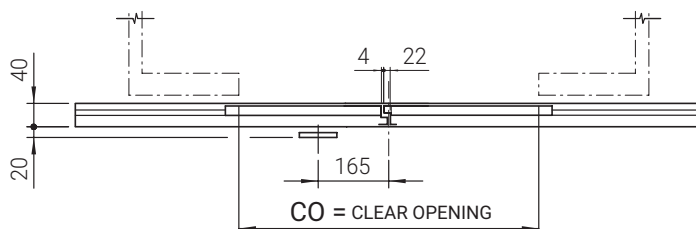
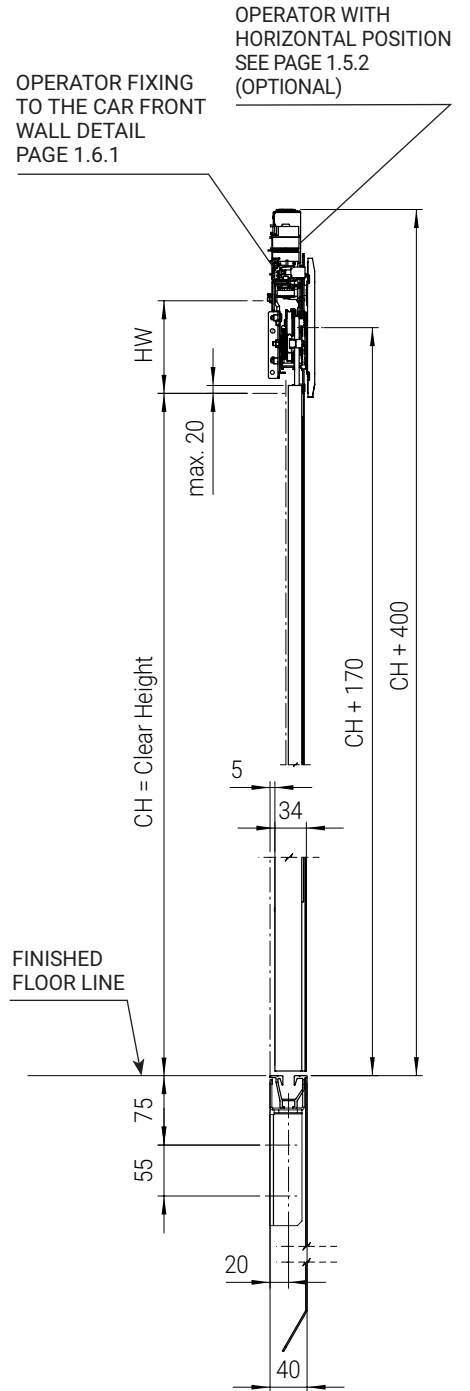
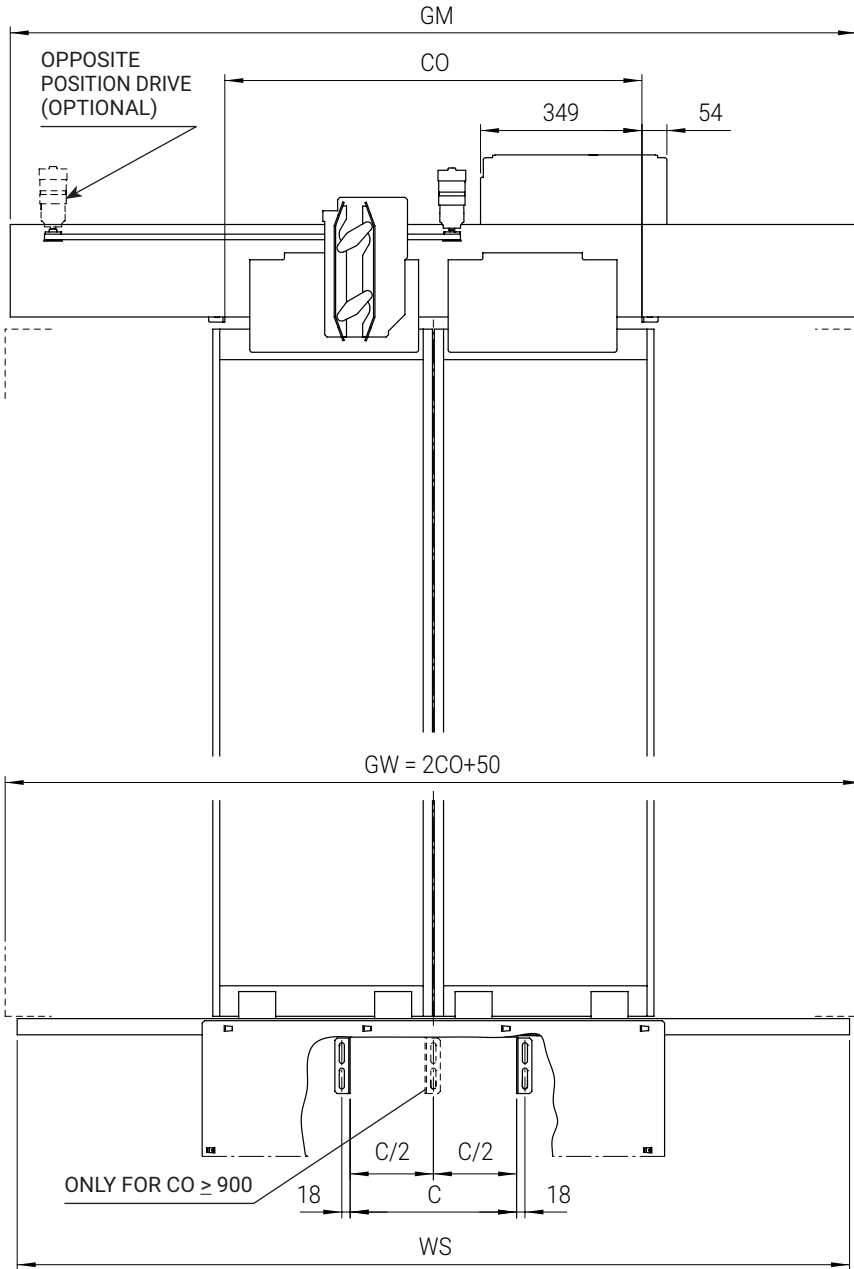

CO	TOTAL WEIGHT Kg LH=2000	GM	GW	WS	C
* 700	61	1480	1450	1400	360
* 750	63	1580	1550	1500	
800	66	1630	1650	1600	
850	68	1680	1750	1700	460
900	72	1830	1850	1800	
950	74	1880	1950	1900	560
1000	77	2030	2050	2000	
1050	79	2080	2150	2100	660
1100	83	2130	2250	2200	

(* Caution: GM dimension larger than GW dimension

Note: Weights referring to not clad doors

FIRE-RESISTANT DOOR

Ty 01/C

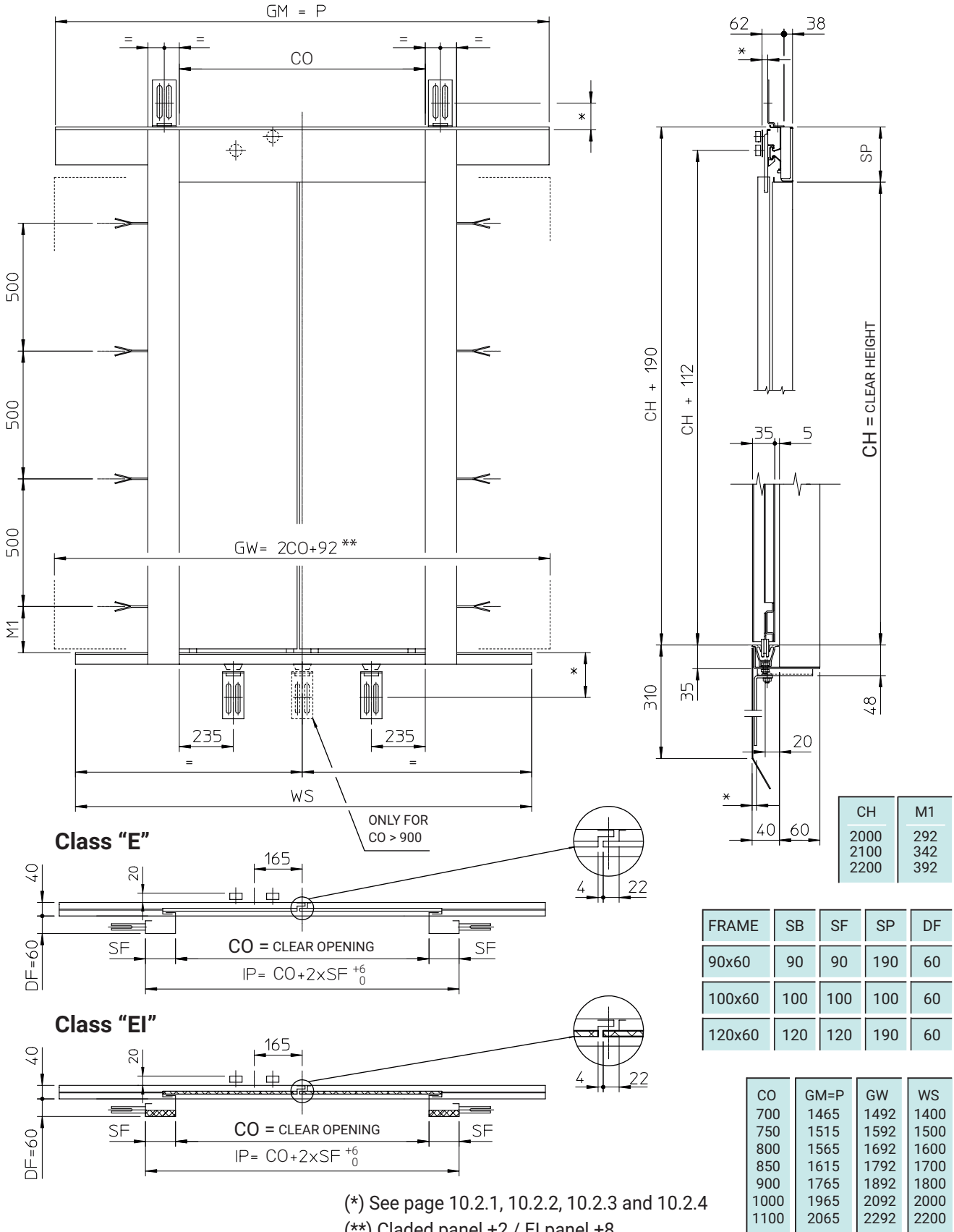

FIRE RESISTANT DOOR WITH LATERAL BIG FRAMES

Ty 01/C

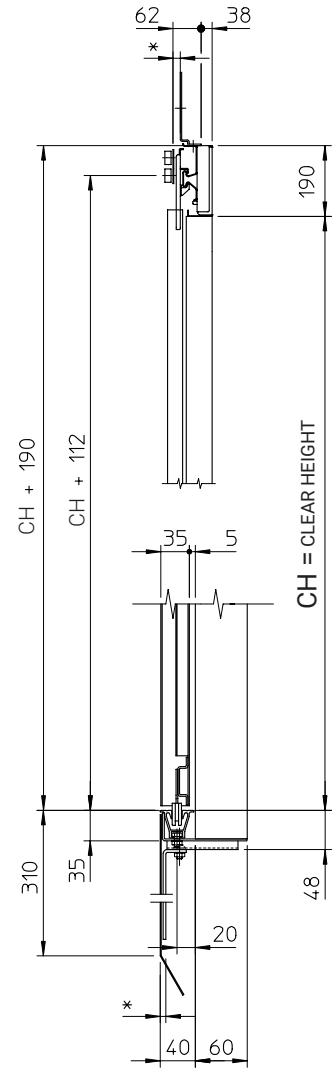
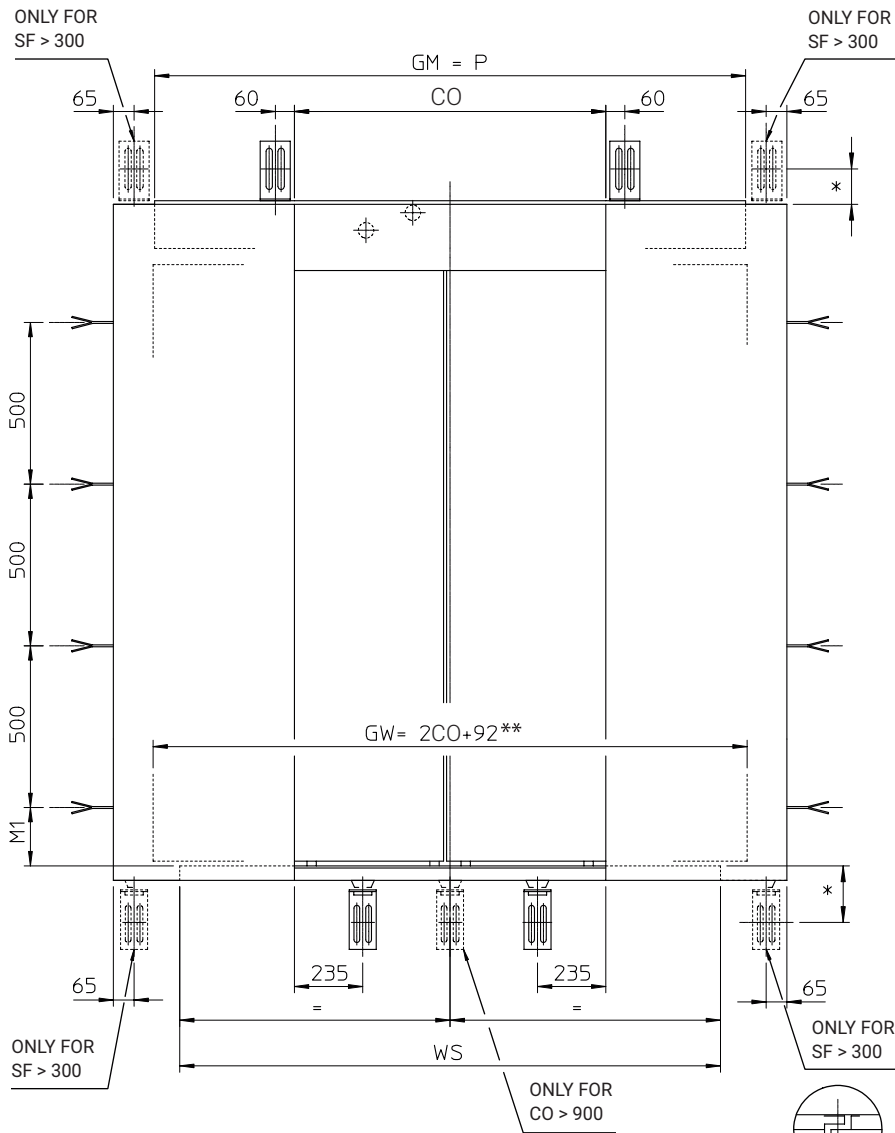

Class "E"

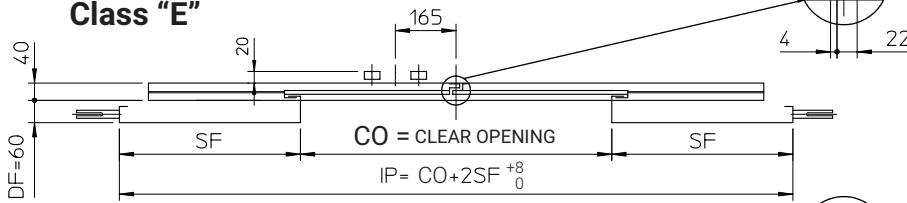

Class "EI"

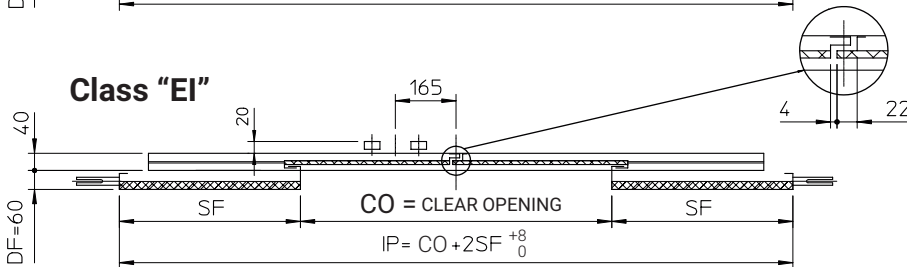

(*) See page 10.2.1 and 10.2.2
 (**) Claded panel +2 / EI +8.

CH	M1
2000	292
2100	342
2200	392

CO	GM=P	GW	WS
700	1465	1492	1400
750	1515	1592	1500
800	1565	1692	1600
850	1615	1792	1700
900	1765	1892	1800
1000	1965	2092	2000
1100	2065	2292	2200

SF/SB min 145 max 650 (5 mm steps)

SHAFT WALL FOR "NICHE INSTALLATION"

Ty 01/C

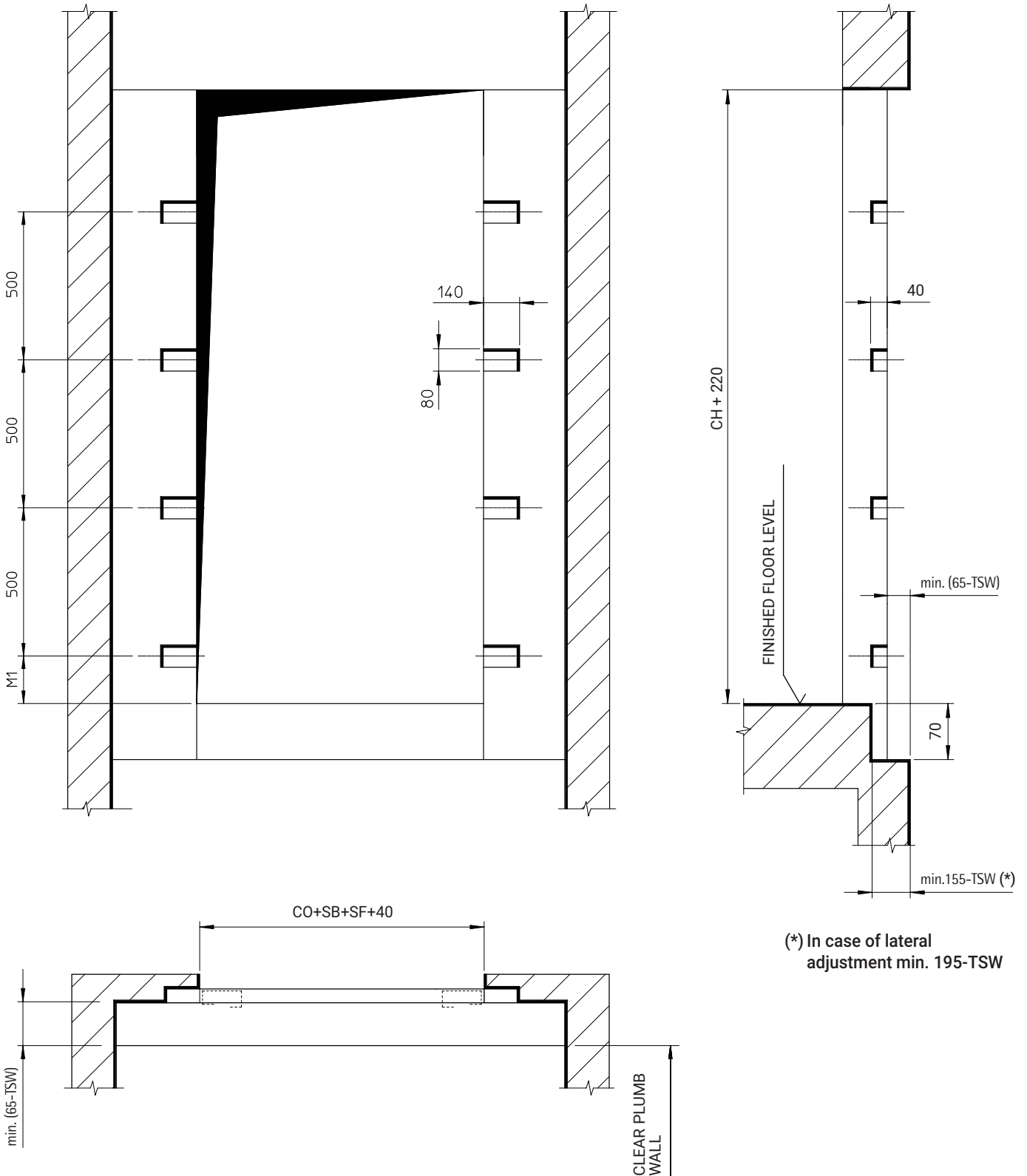

(* In case of lateral adjustment min. 195-TSW

SHAFT WALL FOR "WALL INSTALLATION"

Ty 01/C

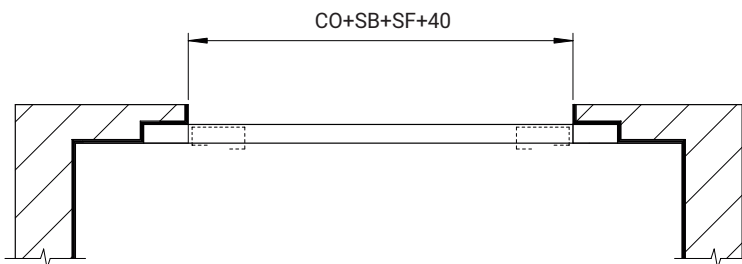
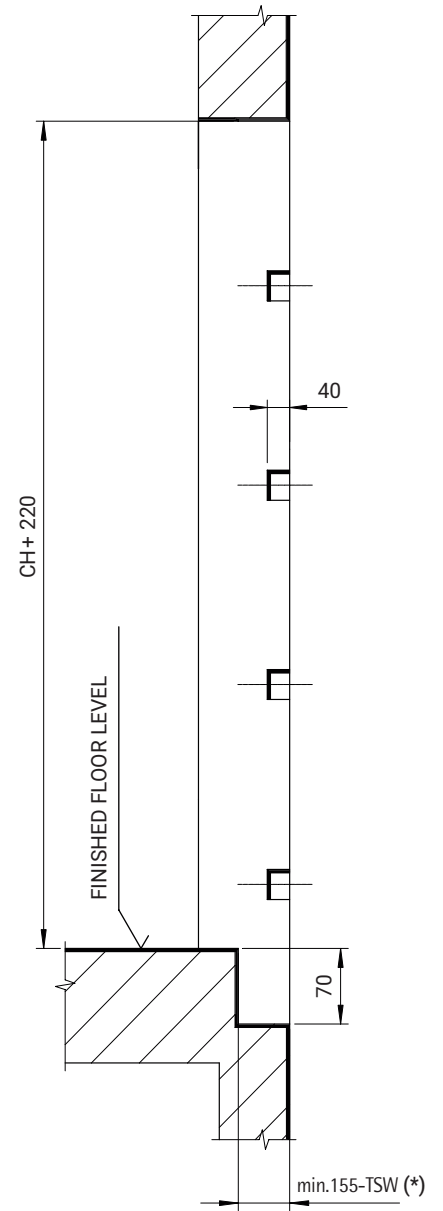
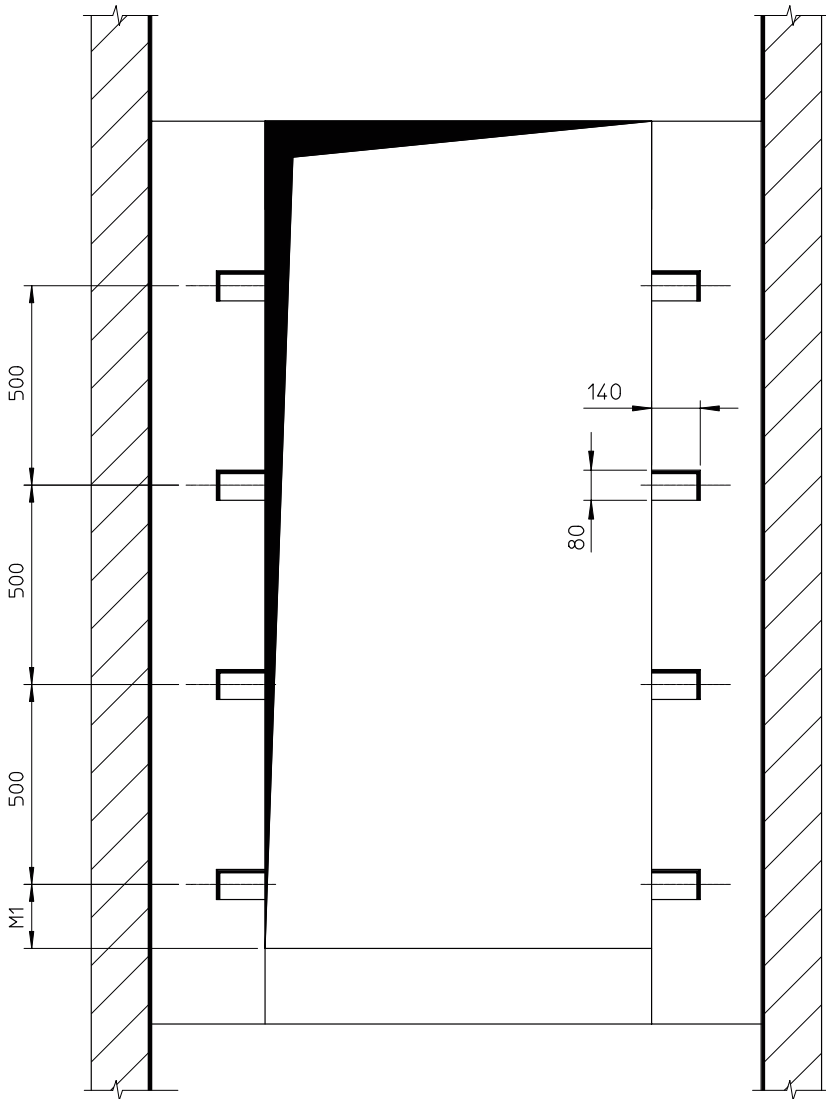

(*) In case of lateral adjustment min. 195-TSW

ARRANGEMENT FOR FIRE-RESISTANT DOOR

Ty 01/C

Ty 02/C

WALL INSTALLATION (TSW = 66÷100)

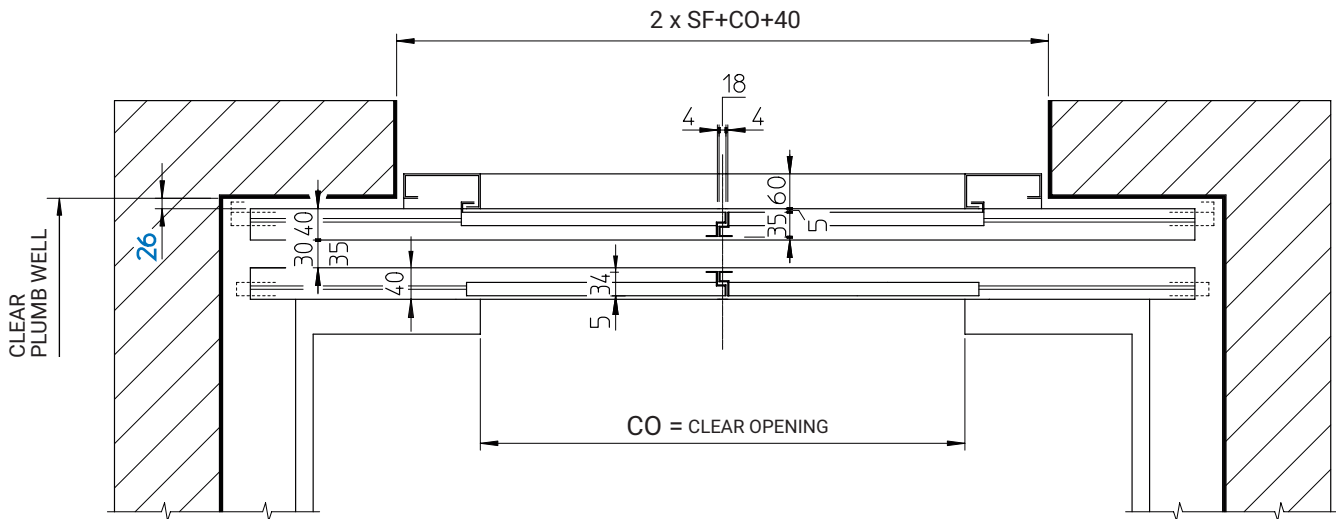

NICHE INSTALLATION (TSW = 20÷65)

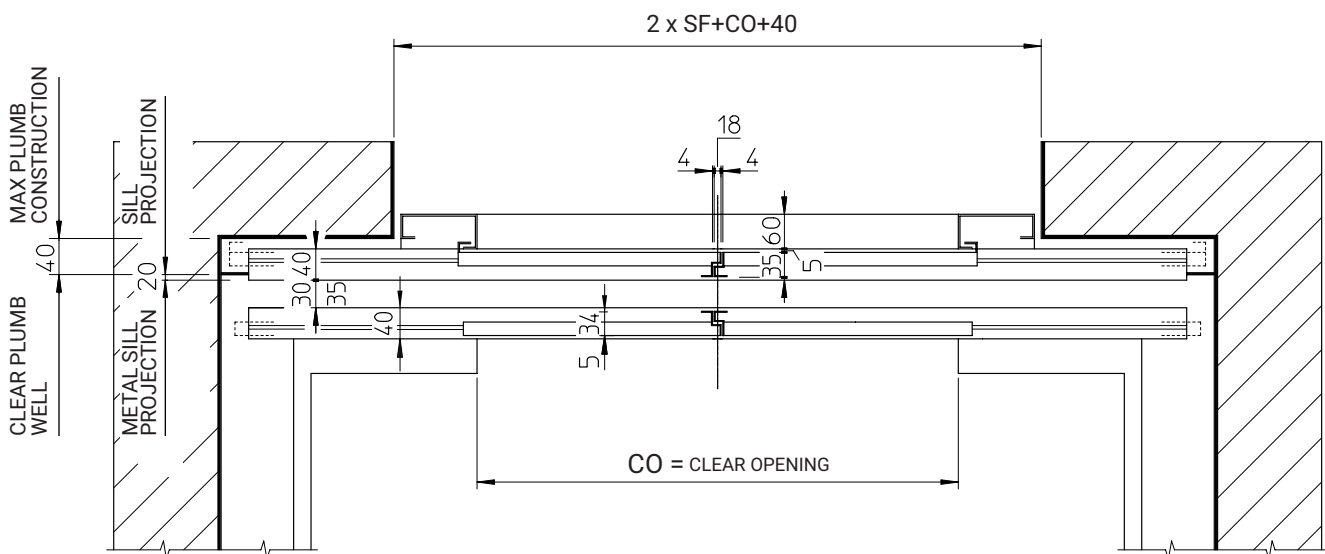

FLOOR LINE FRAME, TY 01/C (OPTIONAL)

Ty 01/C

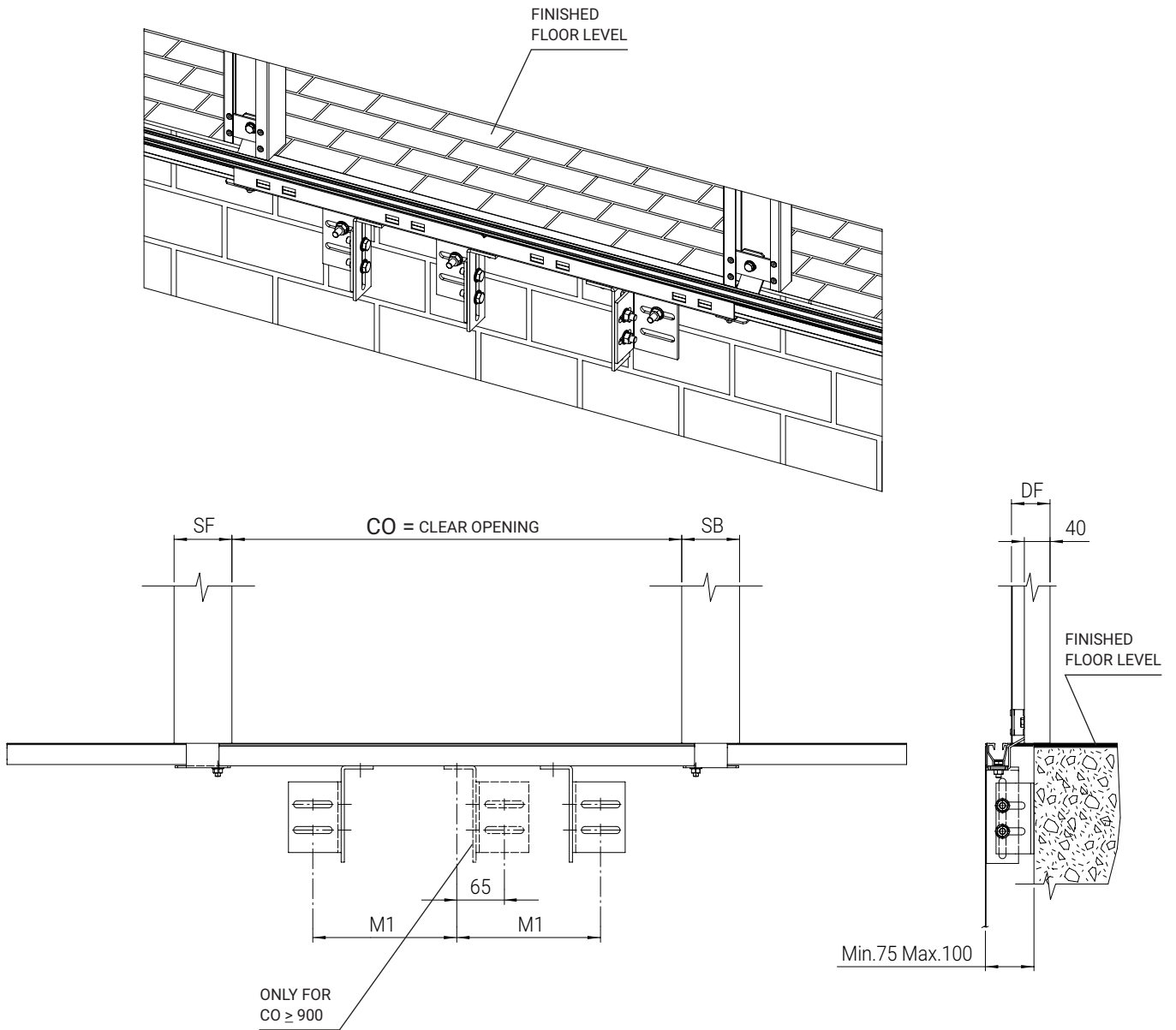

CO	M1
700	215
750	215
800	265
850	265
900	315
950	315
1000	365
1050	365
1100	415

FLOOR LINE FRAME, TY 11/R-L (OPTIONAL)

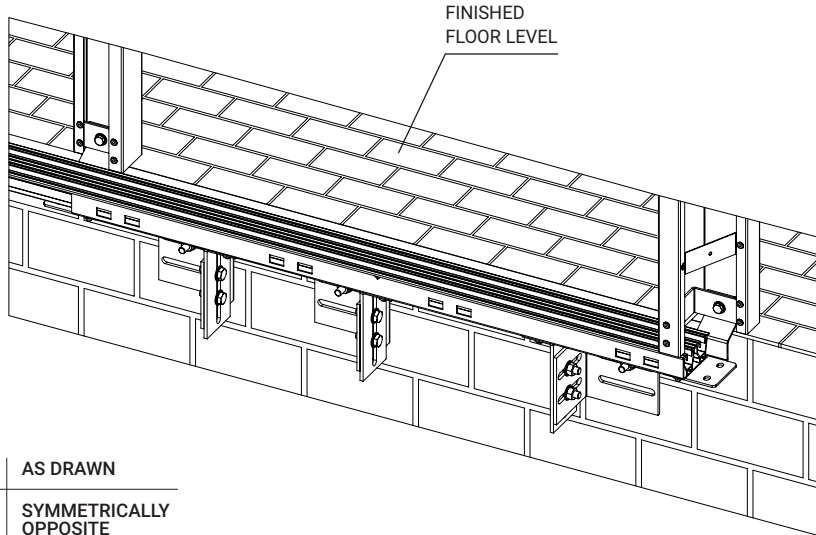

LEFT HAND	AS DRAWN
RIGHT HAND	SYMMETRICALLY OPPOSITE

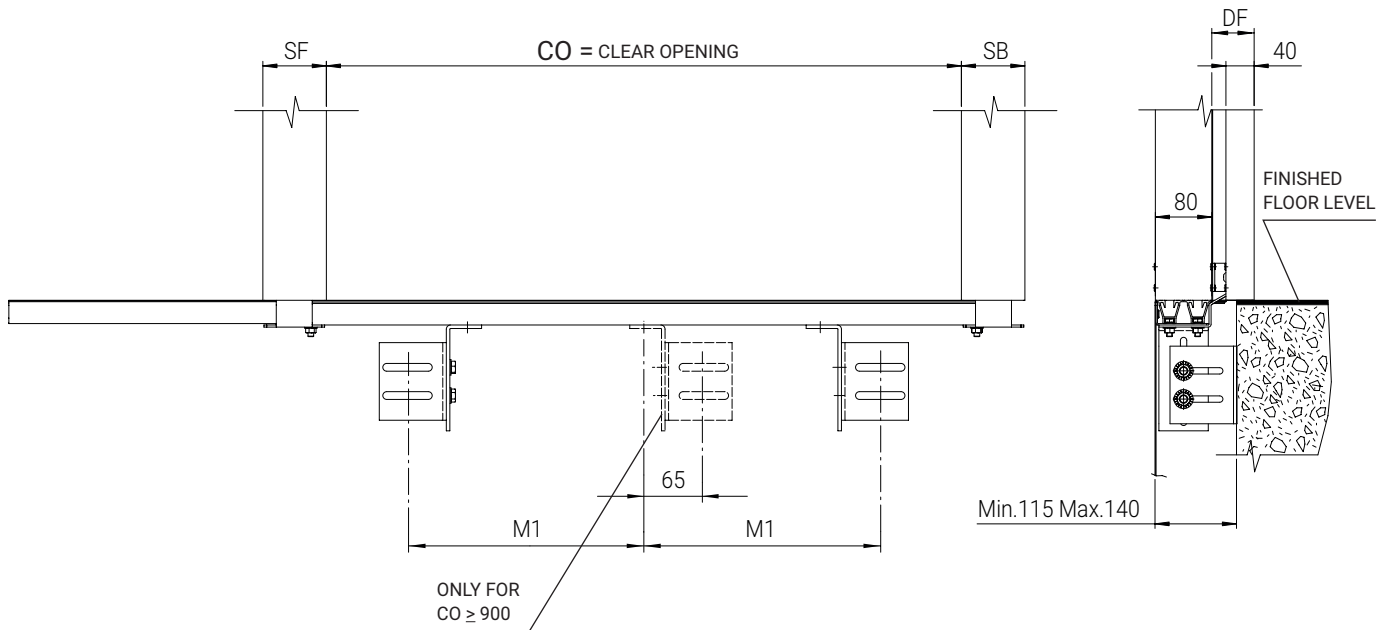

CO	M1
700	215
750	215
800	265
850	265
900	315
950	315
1000	365
1050	365
1100	415

BRACKETS FOR TSW=20÷55 (NICHE INSTALLATION)

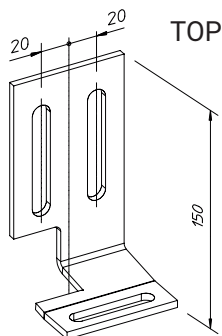
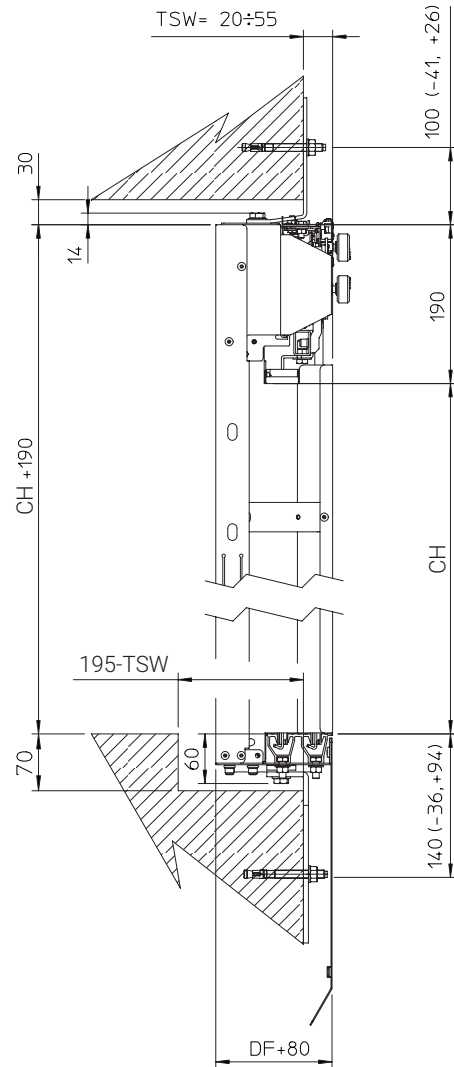
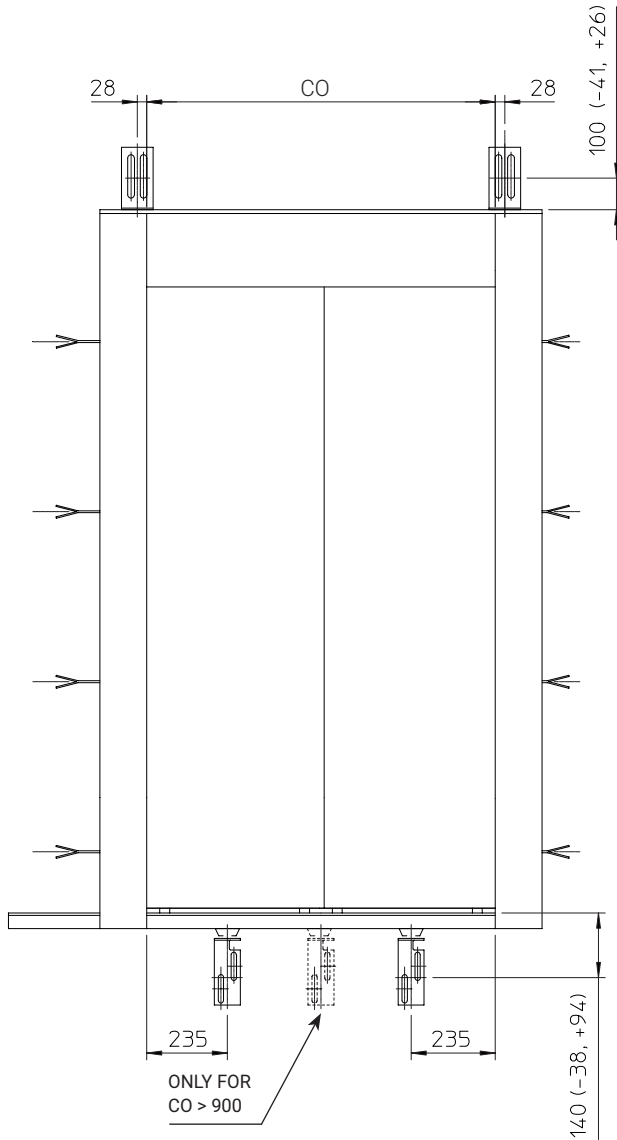
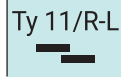

CODE NR. 1013351

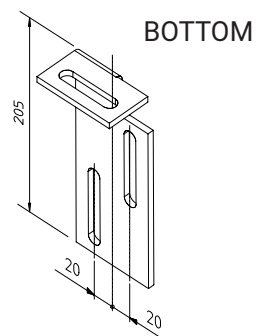

CODE NR. 1006056

BRACKETS FOR TSW=56÷99 (NICHE INSTALLATION)

BRACKETS FOR TSW=100÷140 (WALL INSTALLATION)

Ty 11/R-L

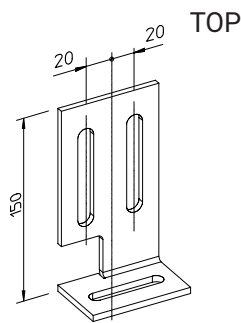
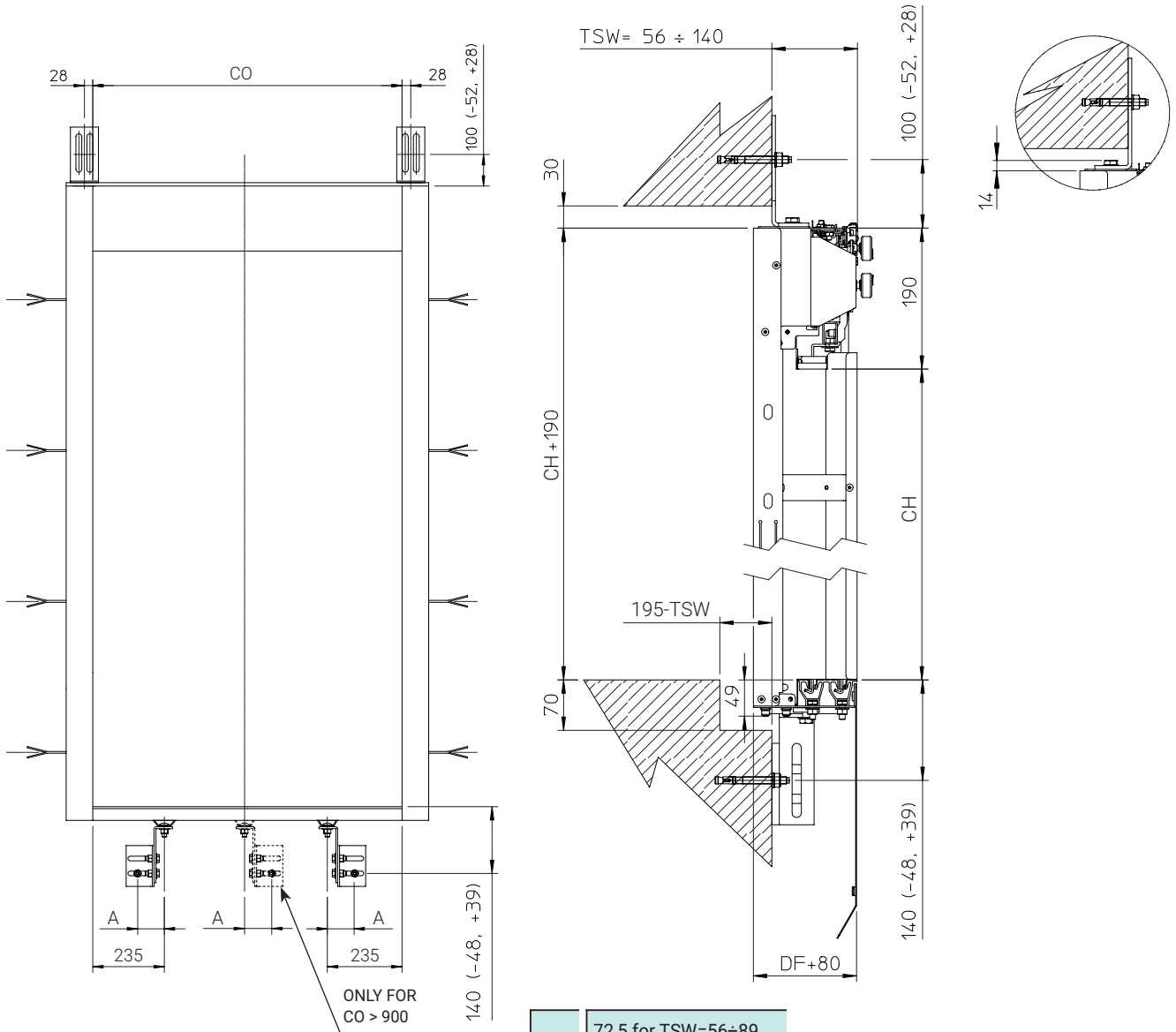

CODE NR. 1020020

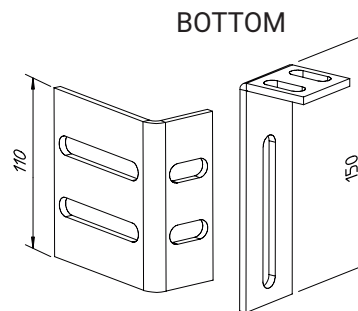

CODE NR. 1033481 CODE NR. 1033485

BRACKETS FOR TSW=80÷99 (NICHE INSTALLATION)

Ty 11/R-L

SP=100

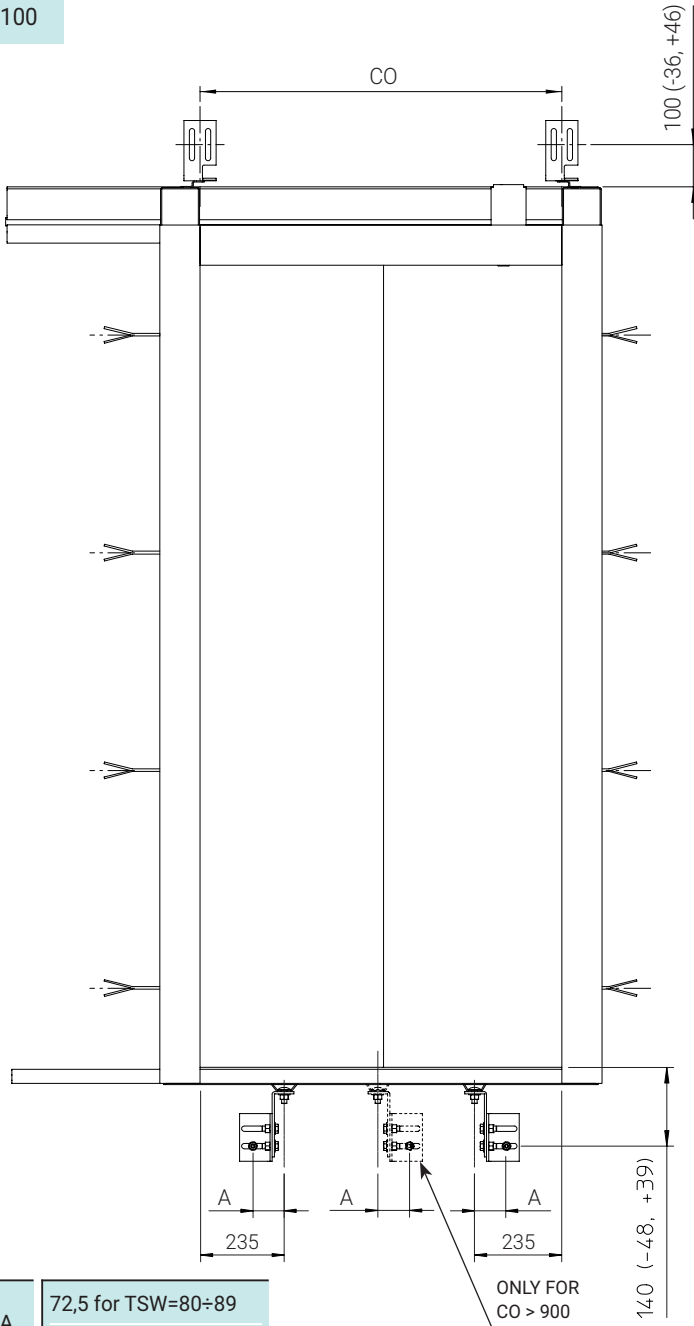

A	72,5 for TSW=80÷89
	55 for TSW=90÷99

ONLY FOR
CO > 900

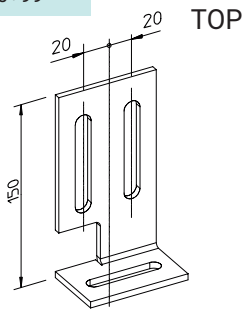
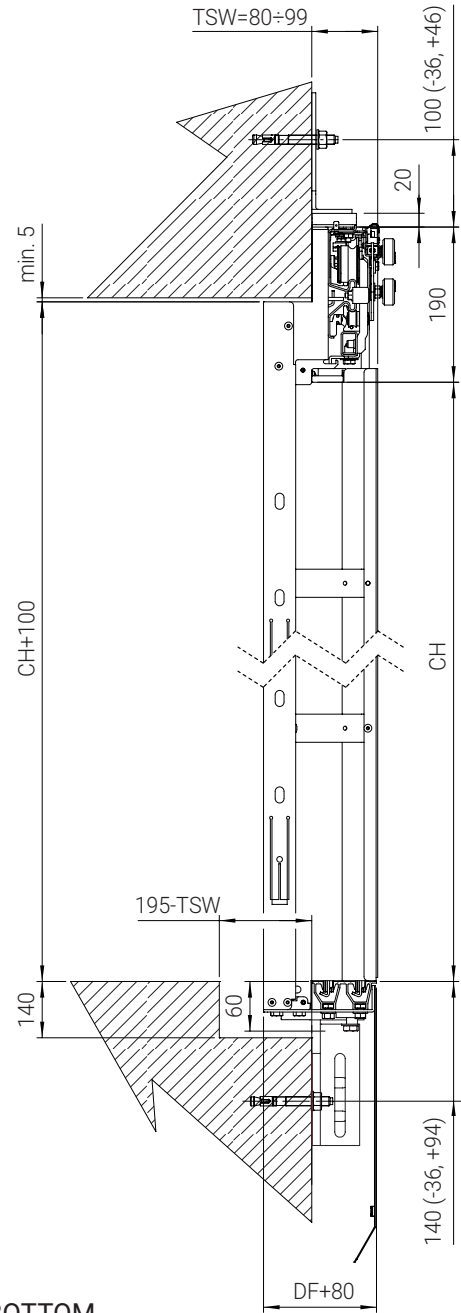

CODE NR. 1020020

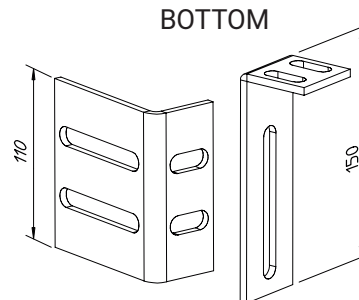

CODE NR. 1033481

CODE NR. 1033485

BRACKETS FOR TSW=100÷140 (WALL INSTALLATION)

Ty 11/R-L

SP=100

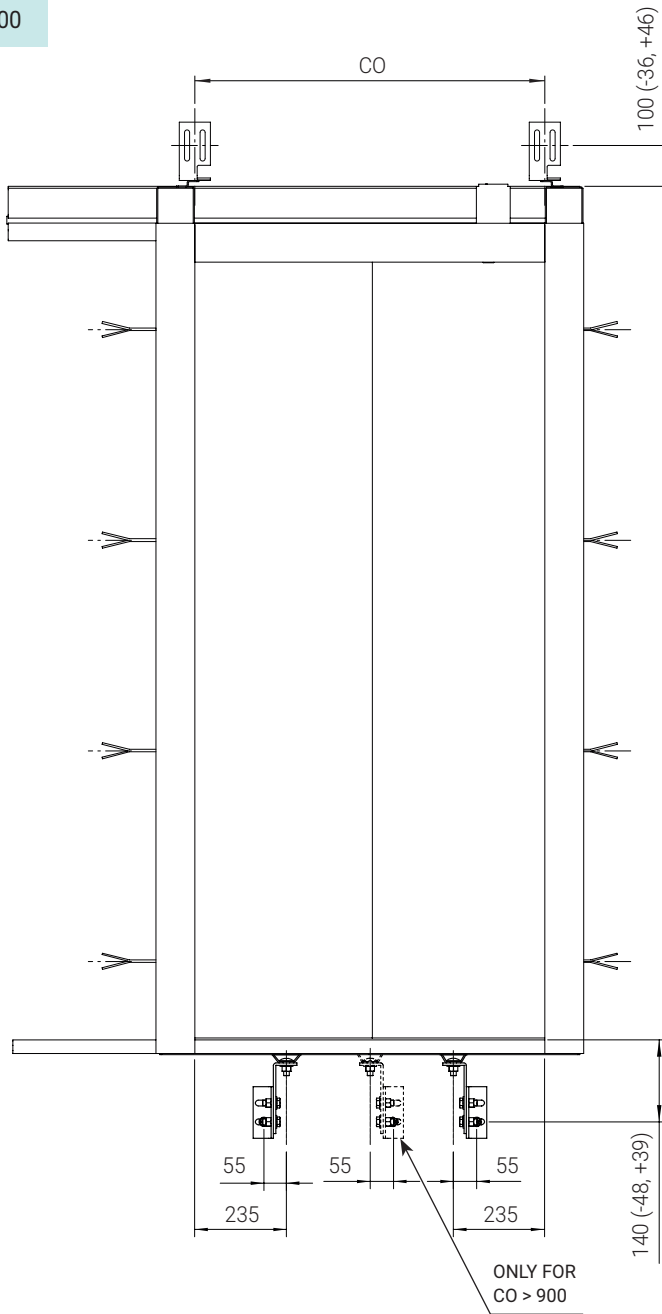

TOP

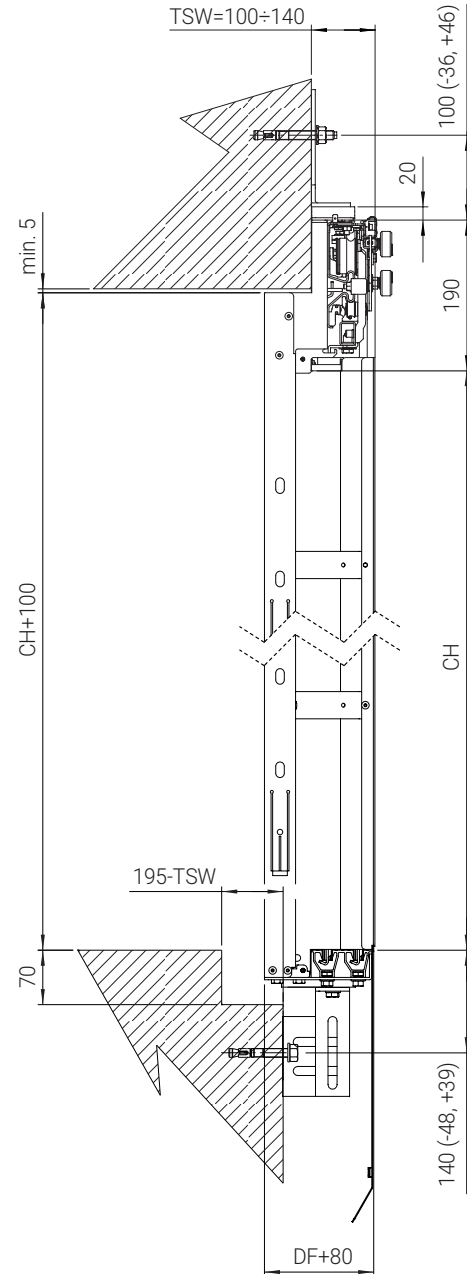

BOTTOM

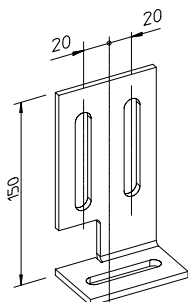

CODE NR. 1020020

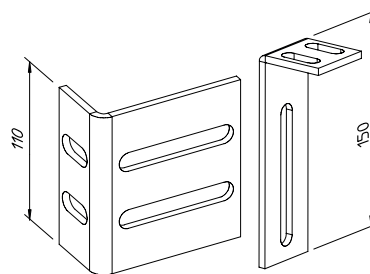

CODE NR. 1033481

CODE NR. 1033485

BRACKETS FOR TSW=20÷55 (NICHE INSTALLATION)

Ty 01/C

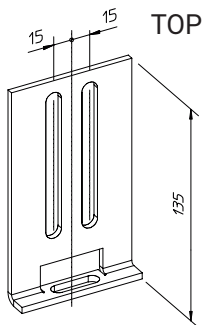
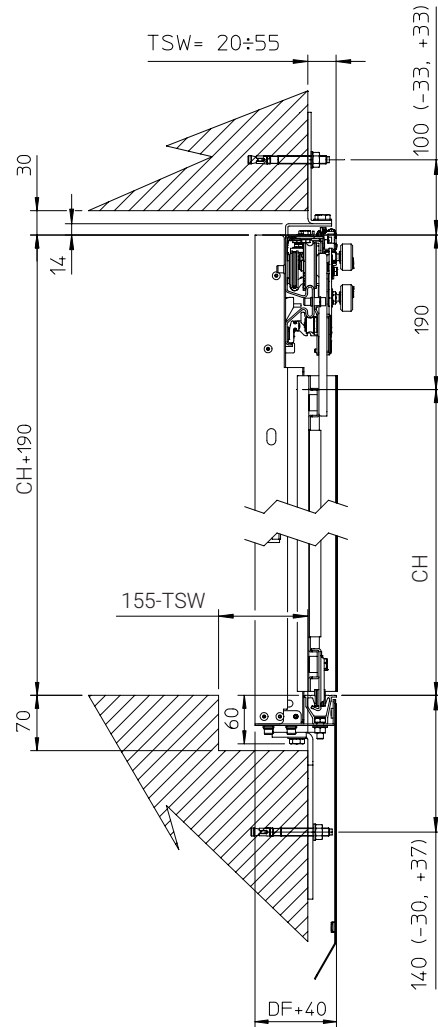
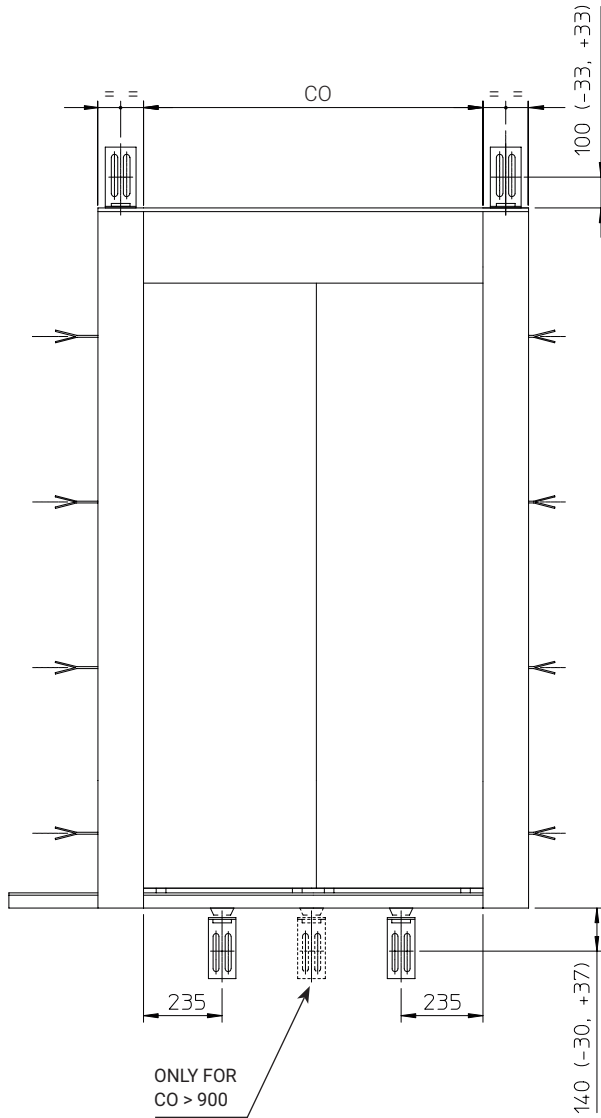

CODE NR. 1018734

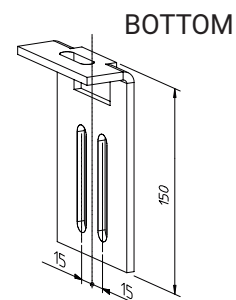

CODE NR. 1017533

BRACKETS FOR TSW=56÷65 (NICHE INSTALLATION)
BRACKETS FOR TSW=66÷100 (WALL INSTALLATION)

Ty 01/C

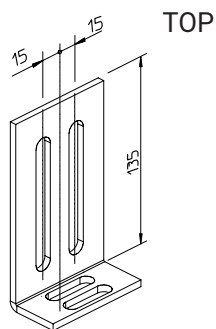
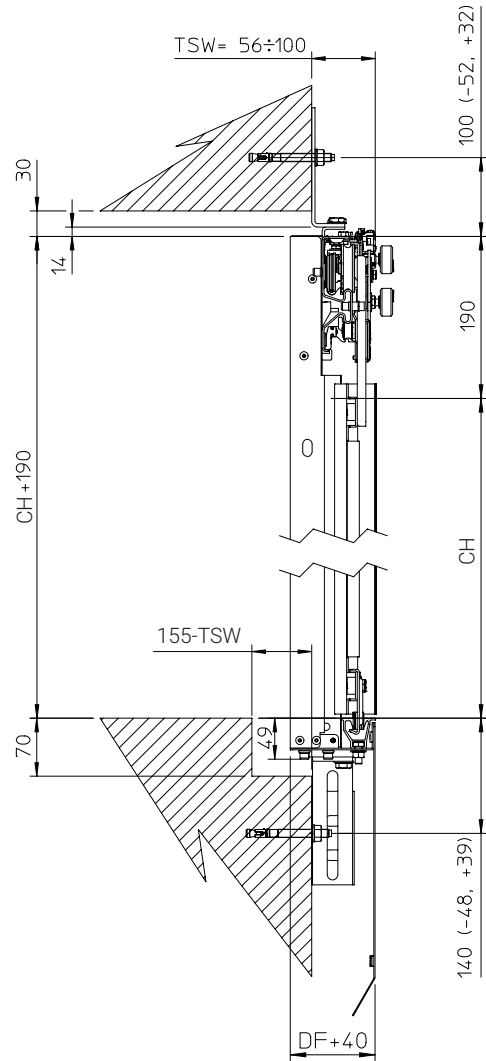
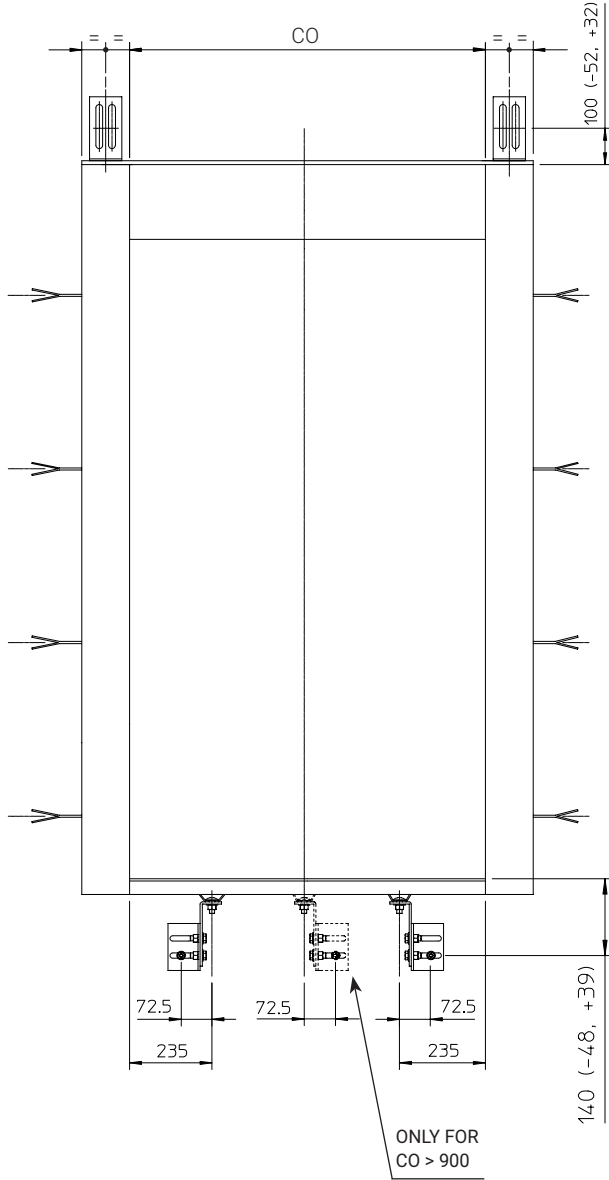

CODE NR. 1020021

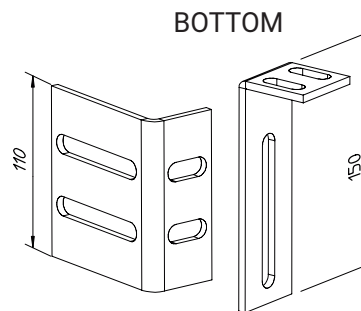

CODE NR. 1033481

CODE NR. 1033485

COVER SILL ASSEMBLY BETWEEN FRAMES (OPTIONAL)

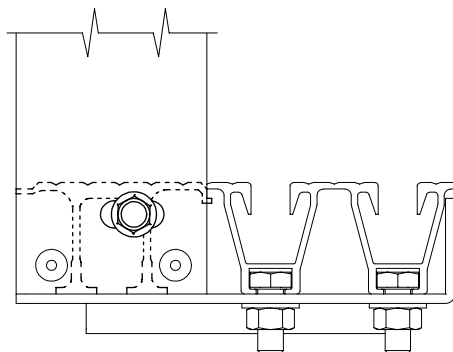
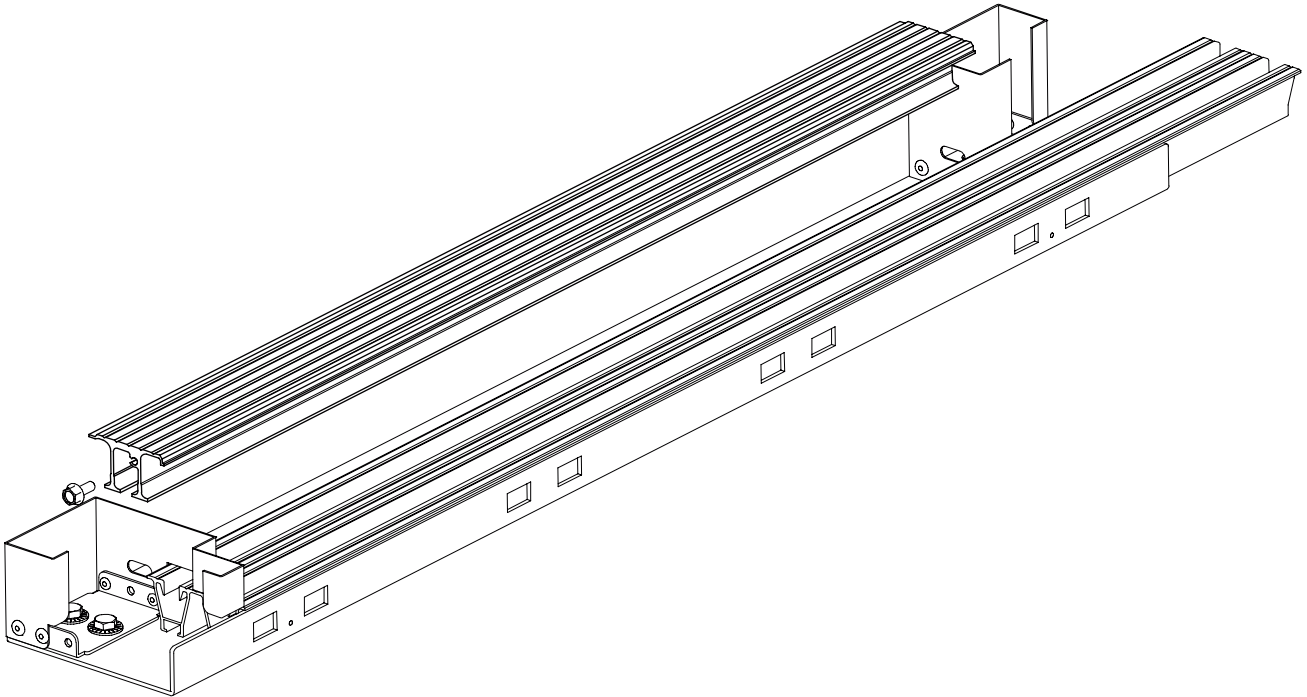

SILL PROTECTION (OPTIONAL)

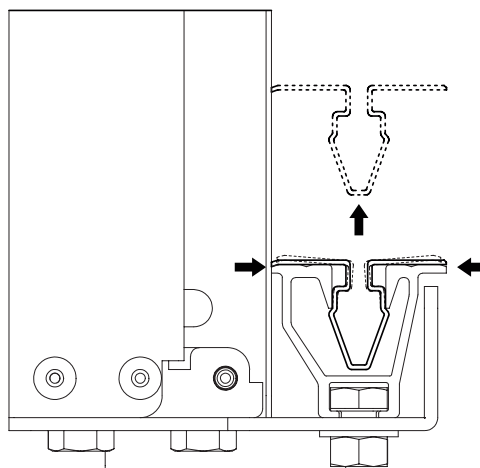
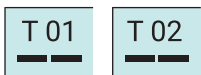
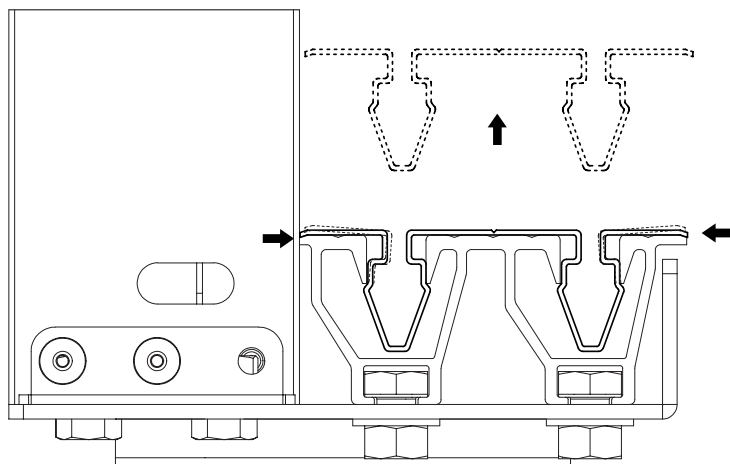
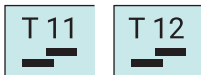
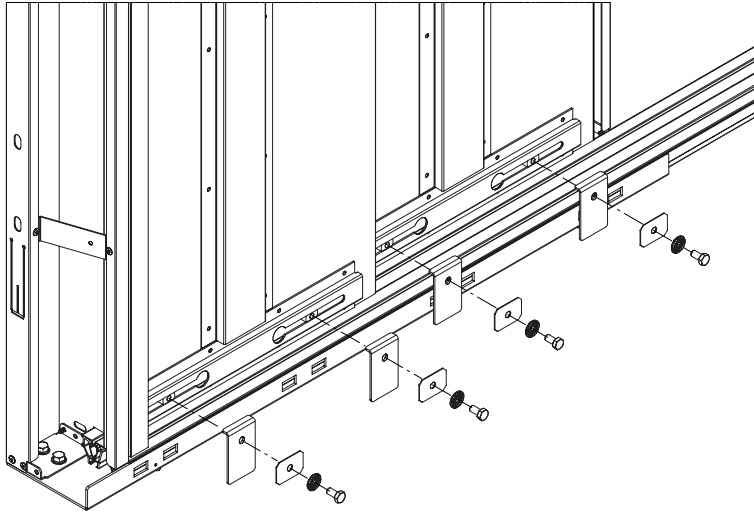

PIT EGRESS (OPTIONAL)

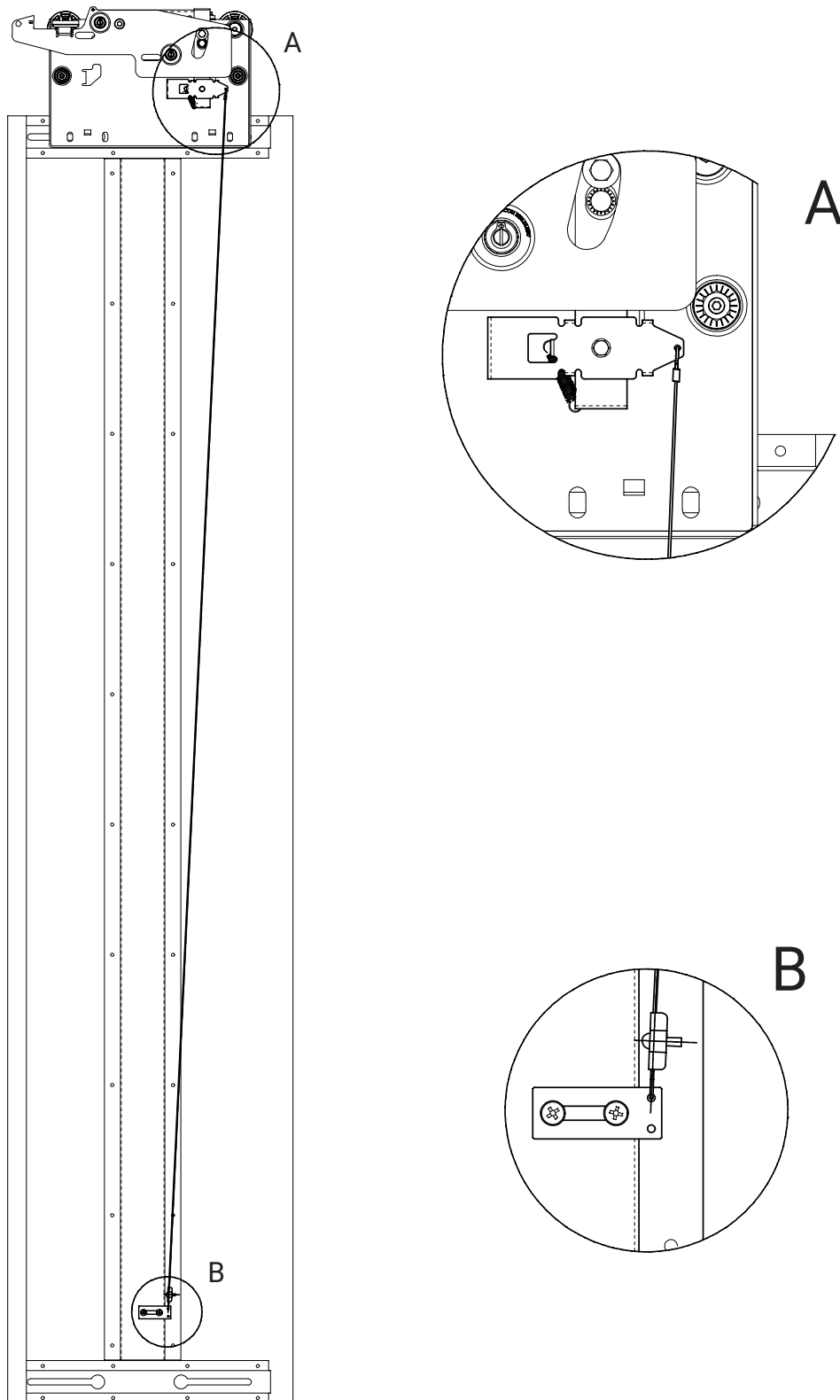

SECURITY SWITCH FOR LOW PIT ACCESS SHORT PIT AND/OR HEAD (OPTIONAL)

T 01

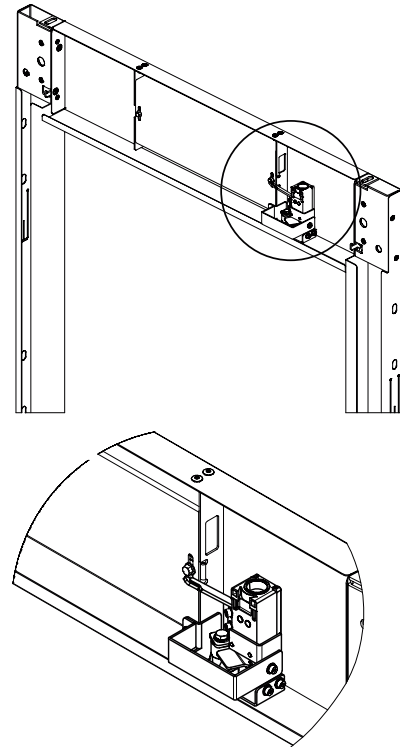
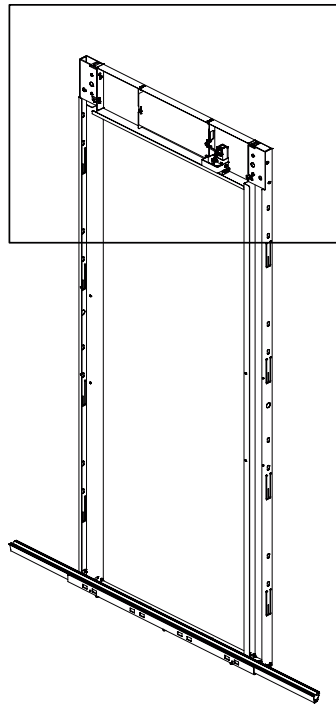

AVAILABLE OPTIONS
24V remote reset
230V remote reset
Without reset

T 11

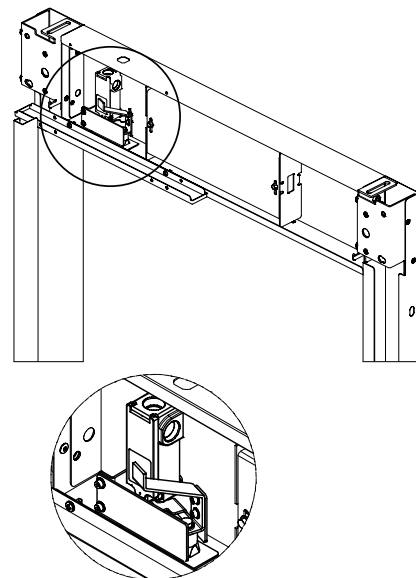
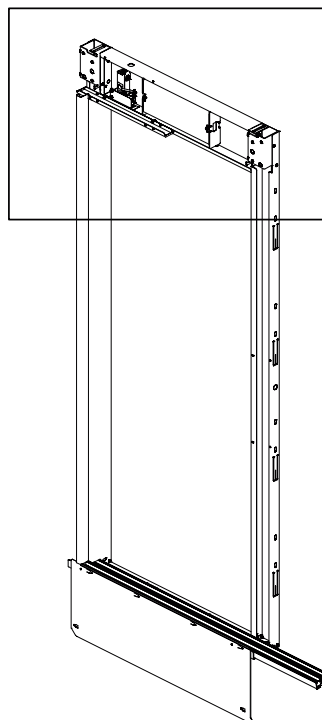

AVAILABLE OPTIONS
24V remote reset
230V remote reset
Without reset

LATERAL ADJUSTMENT (OPTIONAL)

Only available for lateral big frame execution (SB/SF>=145)

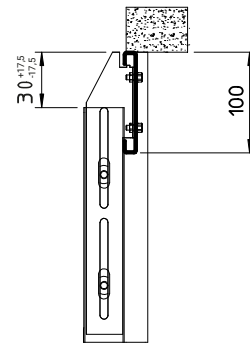
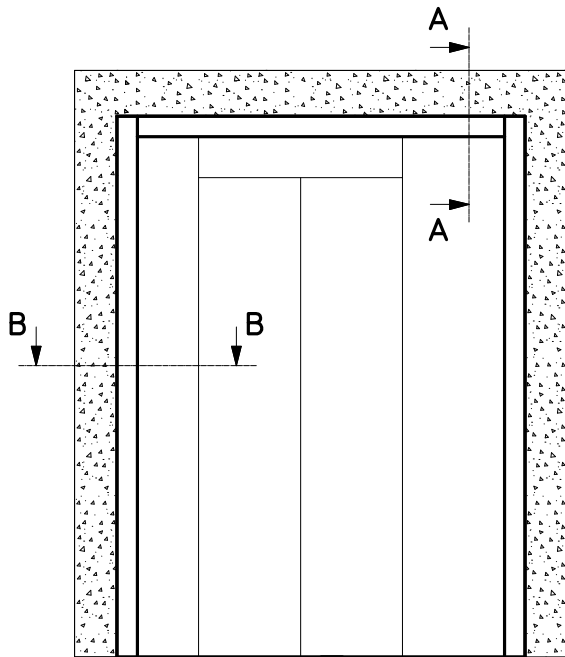

SECTION A-A

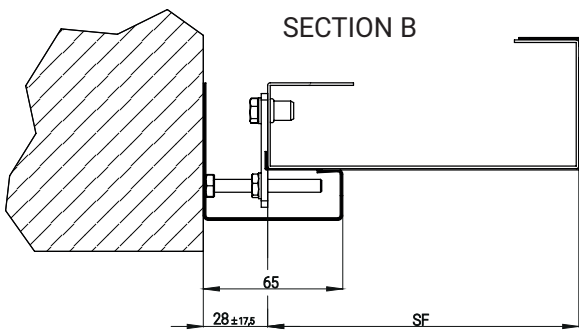

$SF/SB \leq 170$

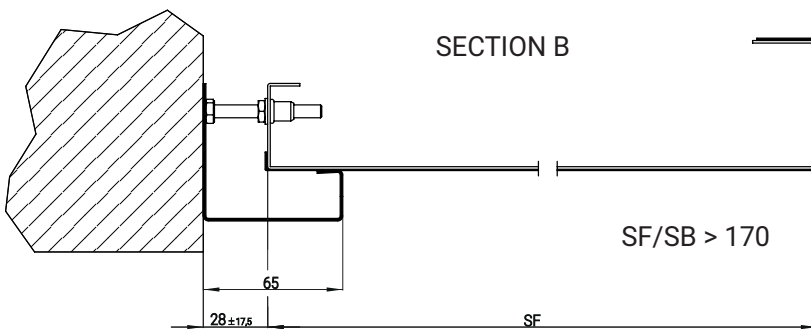

$SF/SB > 170$

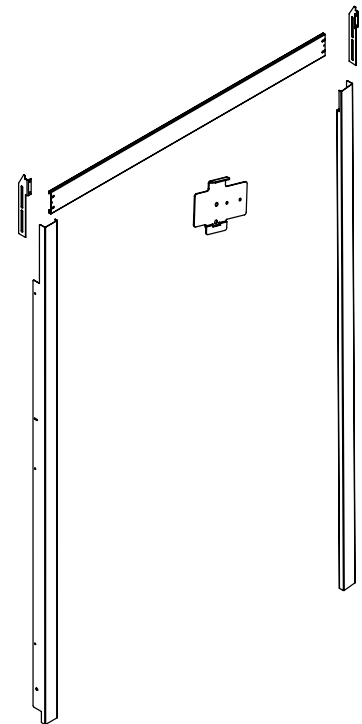

WSE LIGHT CURTAIN FIXING FOR CENTRAL OPENING CAR DOORS, TY 02/C (OPTIONAL)

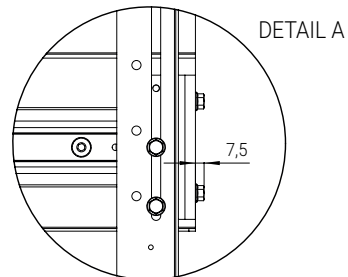
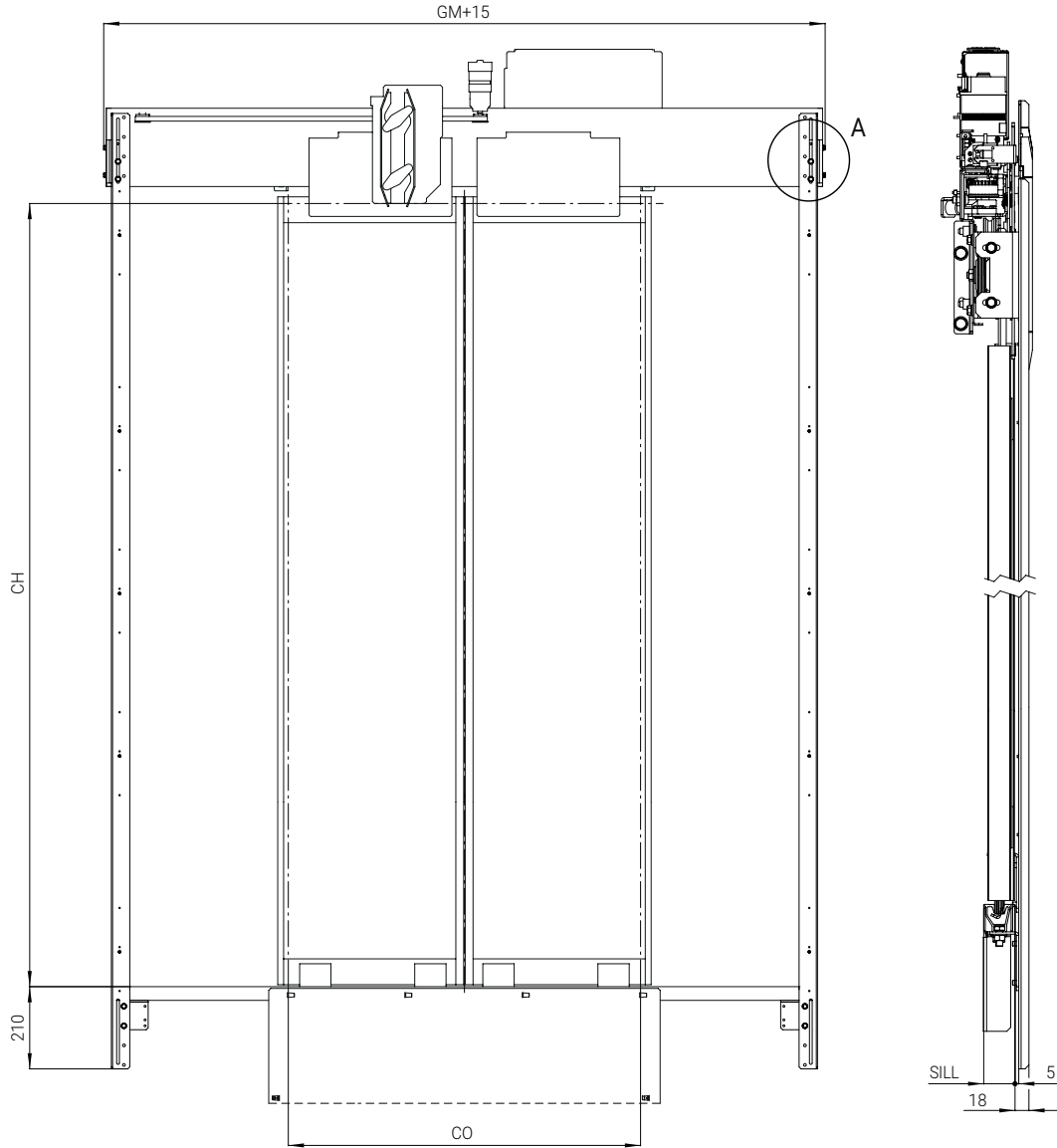

WSE LIGHT CURTAIN FIXING FOR CENTRAL OPENING CAR DOORS, TY 12/R-L (OPTIONAL)

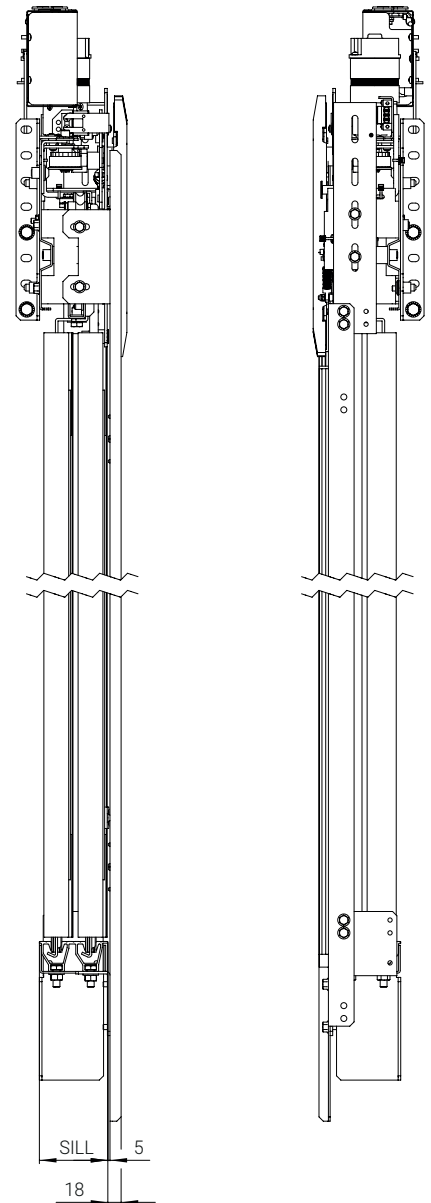
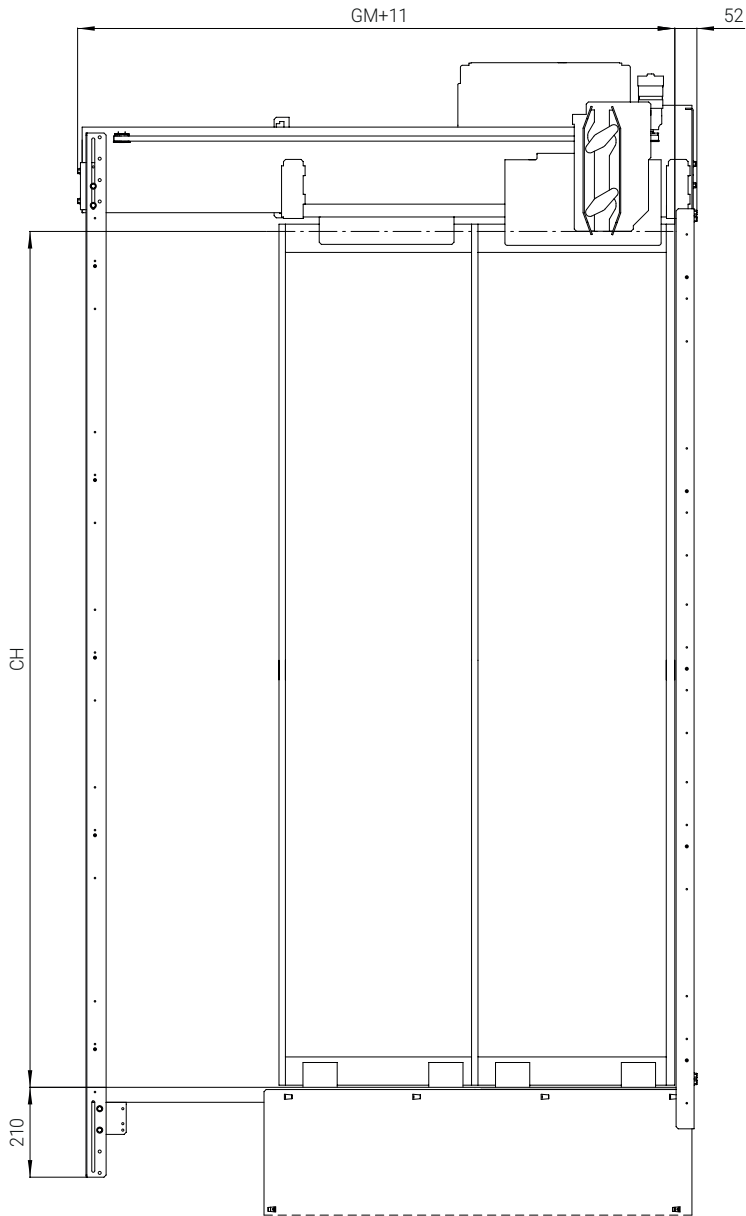



WITTUR

**YOUR GLOBAL PARTNER FOR COMPONENTS,
MODULES AND SYSTEMS IN THE ELEVATOR INDUSTRY**

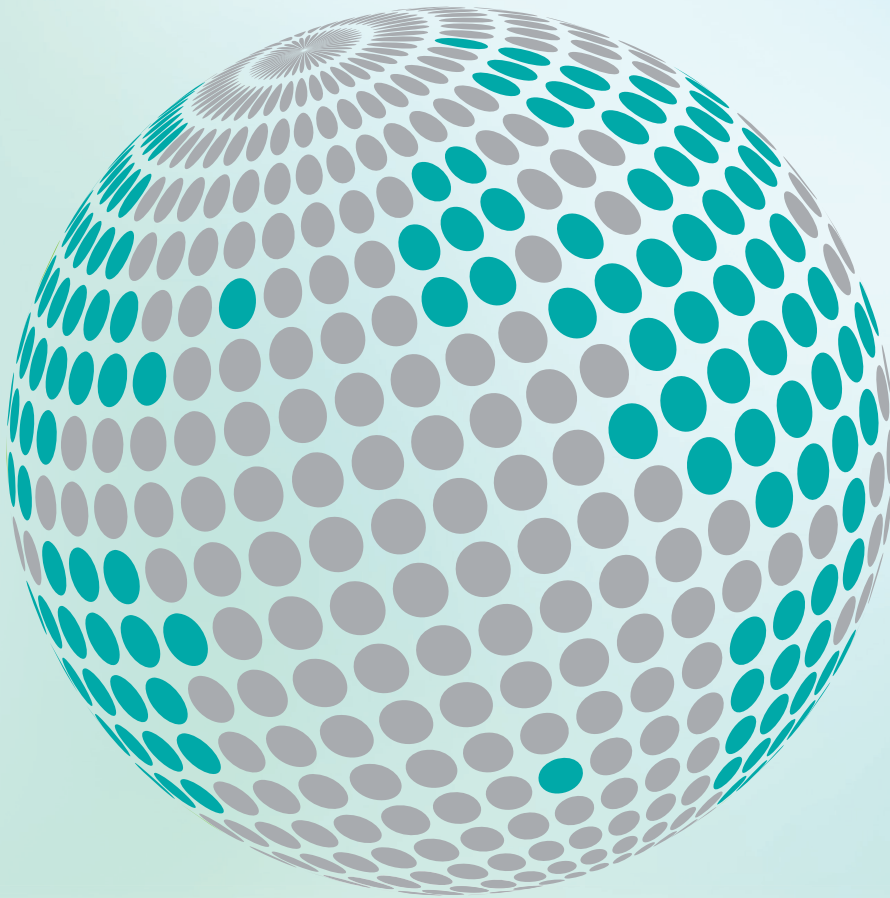

www.wittur.com

More information
about Wittur Group
available on-line.



SELCOM[®]
a WITTUR brand

Liftmaterial
a WITTUR brand

sematic[®]
a WITTUR brand